

Seminar Outline

- Normal Modes Analysis: Basics
- Why is it Useful
- How it Works
 - Principle of Orthogonality
 - Strain Energy
 - Mass Participation
- Available Resources
- Next Training Opportunity on October 15-19, 2012

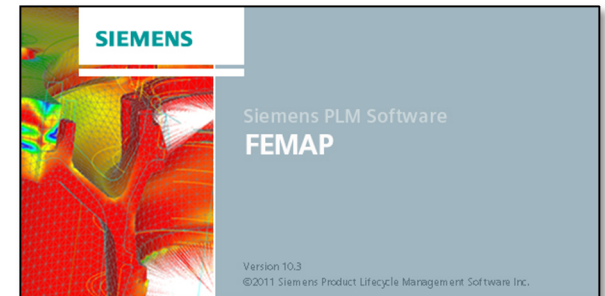

Linear Dynamics: E.O.M. $m \frac{\partial^2 u}{\partial t^2} + c \frac{\partial u}{\partial t} + ku = r(t)$

Eigenvalue problem: undamped free vibration: $m \frac{\partial^2 u}{\partial t^2} + ku = 0$

Assuming a solution of the form: $u = u_0 \sin \omega t$

Then: $[k - \omega^2 m] \{u_0\} = 0$

For non-trivial solutions (i.e., solutions that are more than just zeros):

$[k - \omega^2 m] = 0$ Giving us the well know frequency relationship: $\omega = \sqrt{\frac{k}{m}}$

Why it is Useful: Just Basic Goodness of Normal Modes

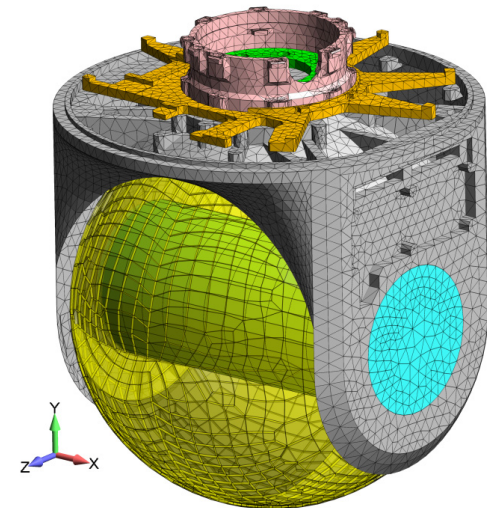
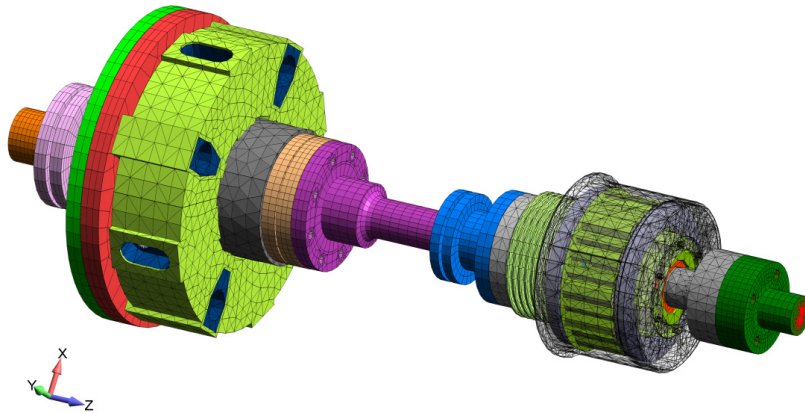
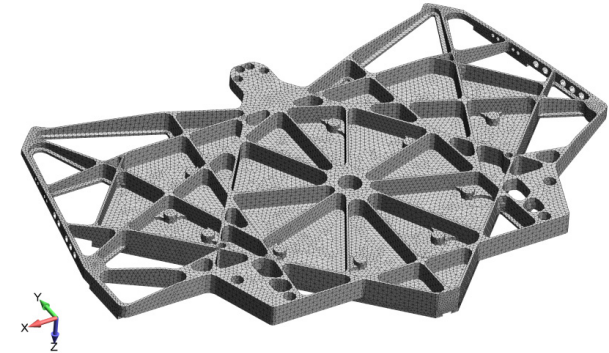
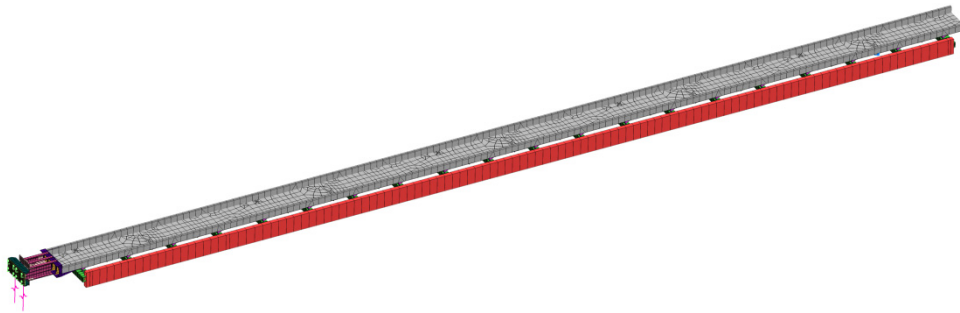

Why it is Useful: Just Basic Goodness of Normal Modes

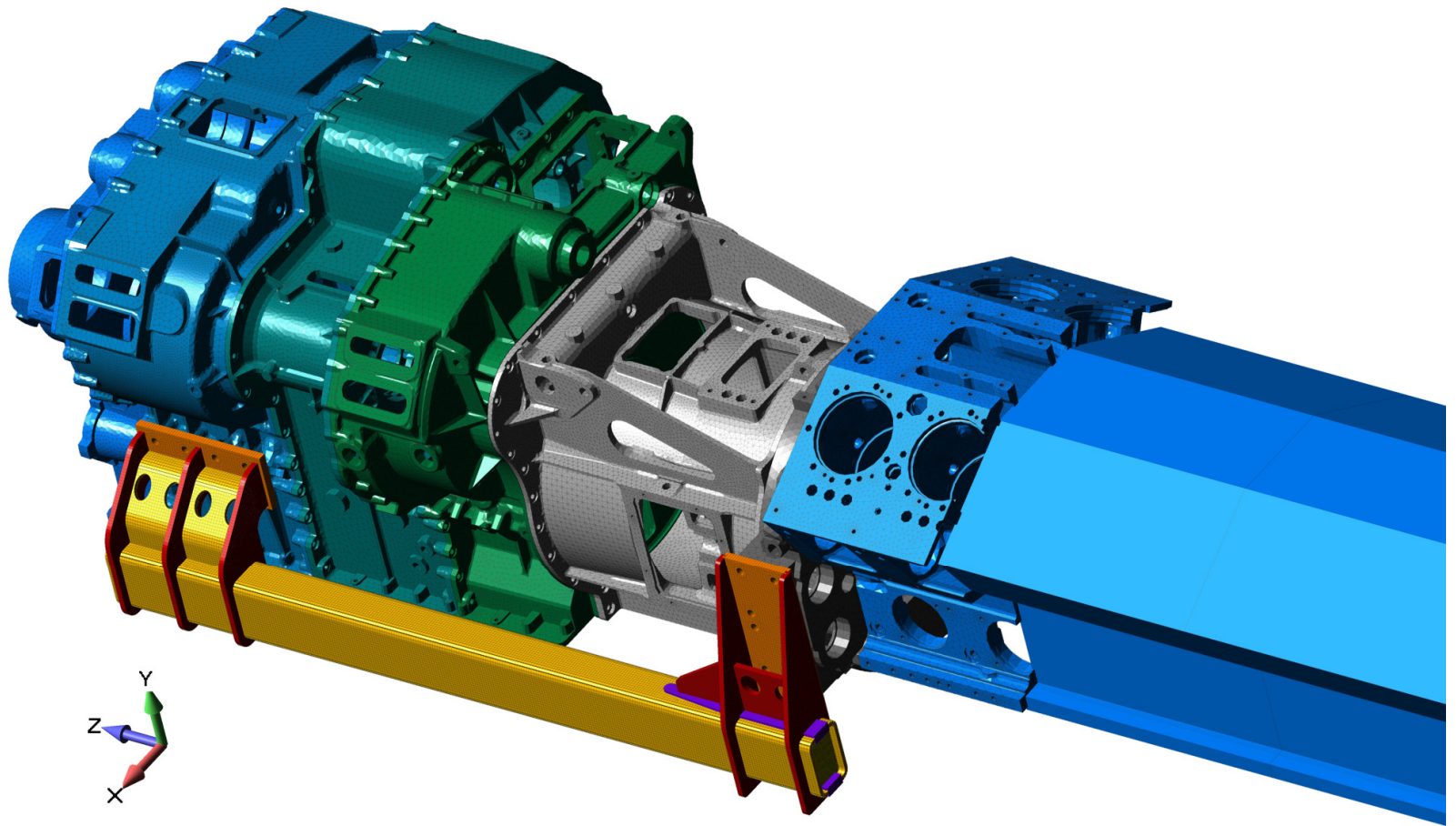

Why it is Useful: PSD Analysis (*Frequency Domain Analysis*)

- ✓ Fatigue
- ✓ Wind Turbine
- ✓ Air flow over a wing
- ✓ Acoustic Input from Jet Engine Exhaust
- ✓ Earthquake Ground Motion
- ✓ Wheels running over a Rough Road
- ✓ Ocean Wave Loads on Offshore Platforms

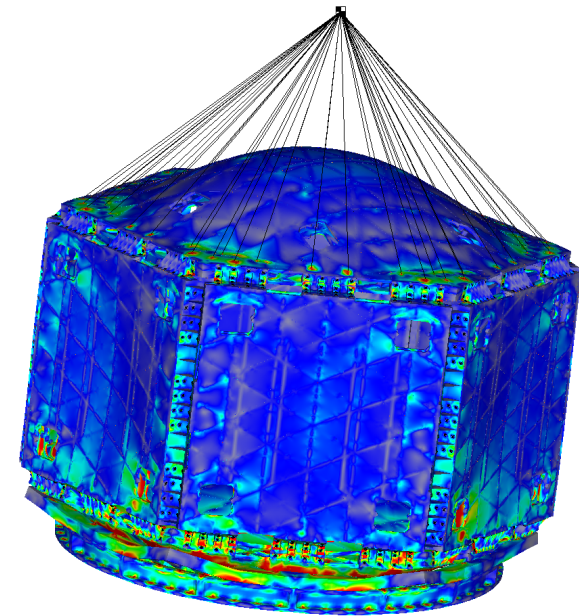
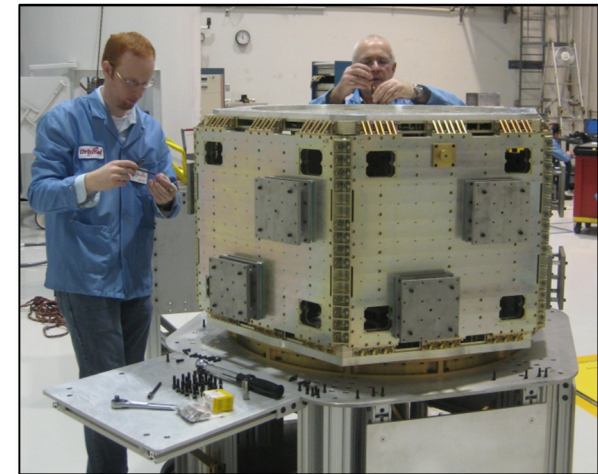

Why it is Useful: Earthquake Analysis

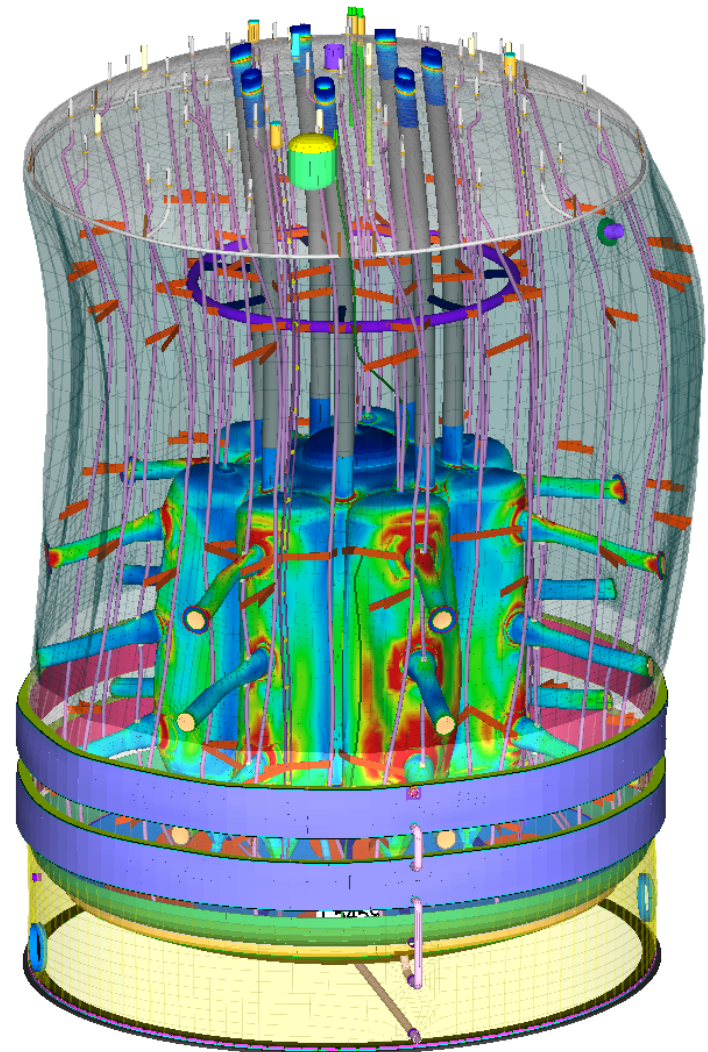

Why it is Useful: Modal Frequency Sweep

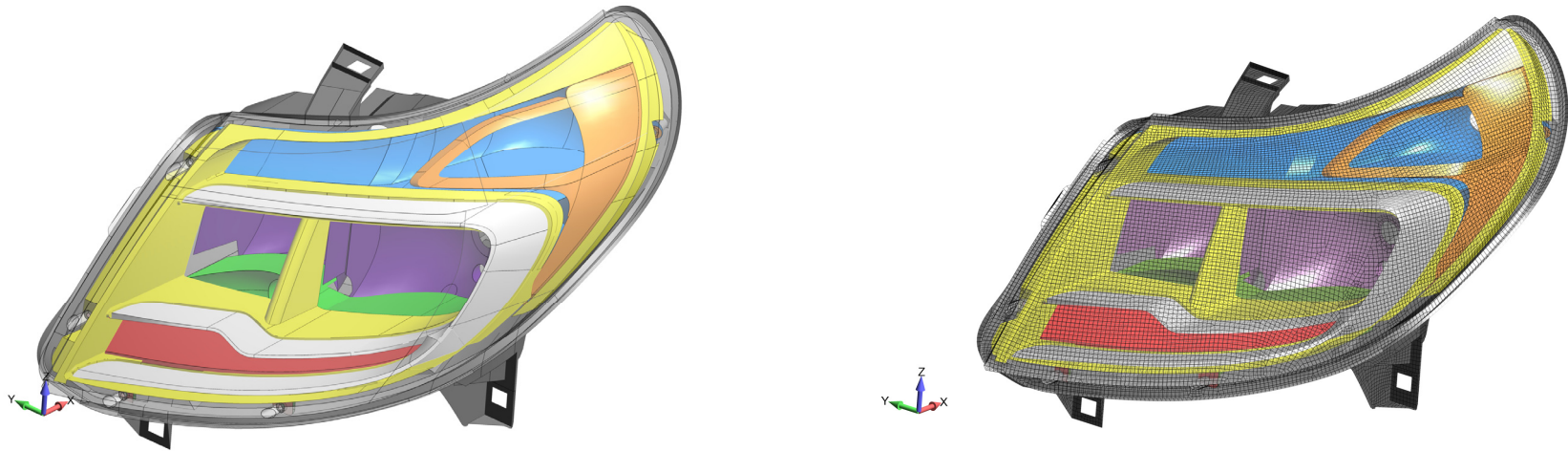

Why it is Useful: NVH

SIEMENS

Mercedes Usage of NX Nastran

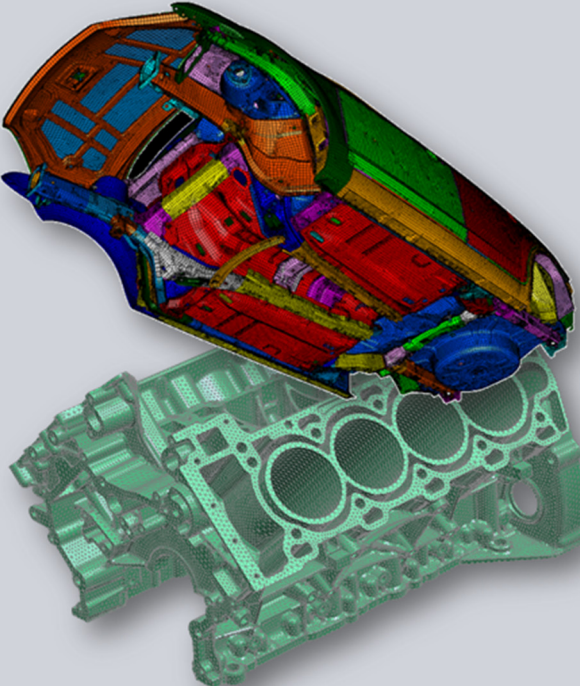

Usage

- ▶ Body/Chassis NVH analyses
 - ▶ Rough road transient
 - ▶ Engine vibration
 - ▶ Wheel unbalance
 - ▶ Interior noise acoustics – with interface to SFE Akusmod
 - ▶ Large eigensolutions – with interface to CDH AMLS
 - ▶ Brake squeal frequency analysis
 - ▶ ...
- ▶ Powertrain
 - ▶ Thermal stress of exhaust systems
 - ▶ Drivetrain vibrations from gear mesh
 - ▶ Powertrain frequency analysis
 - ▶ Powertrain radiation with interface to Sysnoise

Trends

- ▶ Larger full vehicle models
- ▶ More integrations with other solutions such as acoustics, durability, MBD

Page 9

© 2007. Siemens Product Lifecycle Management Software Inc. All rights reserved

Siemens PLM Software

Normal Modes / Eigenvalue problem: undamped free vibration

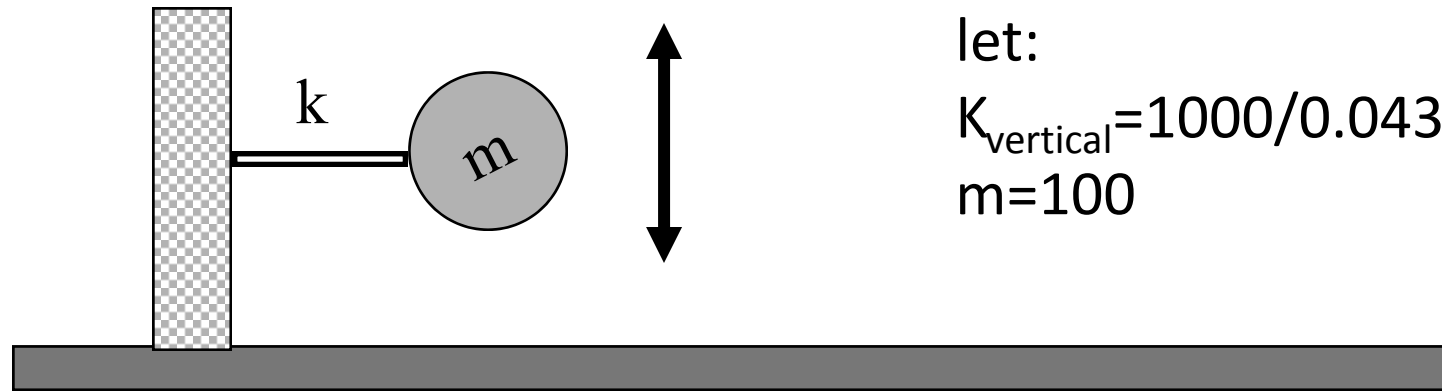

let:
 $K_{\text{vertical}} = 1000 / 0.0435$
 $m = 100$

$$\omega = \sqrt{\frac{k}{m}} = \sqrt{\frac{23,000}{100}} = 15.16 \text{ rad/sec}$$

NX Nastran reports frequencies in cycles per second. Hence, 15.16 radians/sec is equal to 2.41 cycles/sec.

Example Model: Normal Modes Validation Start.modfem
 Simple CBUSH with Mass Element
 Focus: Units | Theory | Why Only Three Modes?

Normal Modes / Eigenvalue problem: Principal of Orthogonality

- Even basic normal modes analysis can be confusing
- Basic beam model with a pinned support is interrogated
- Is it logical?
- Why are there double modes?

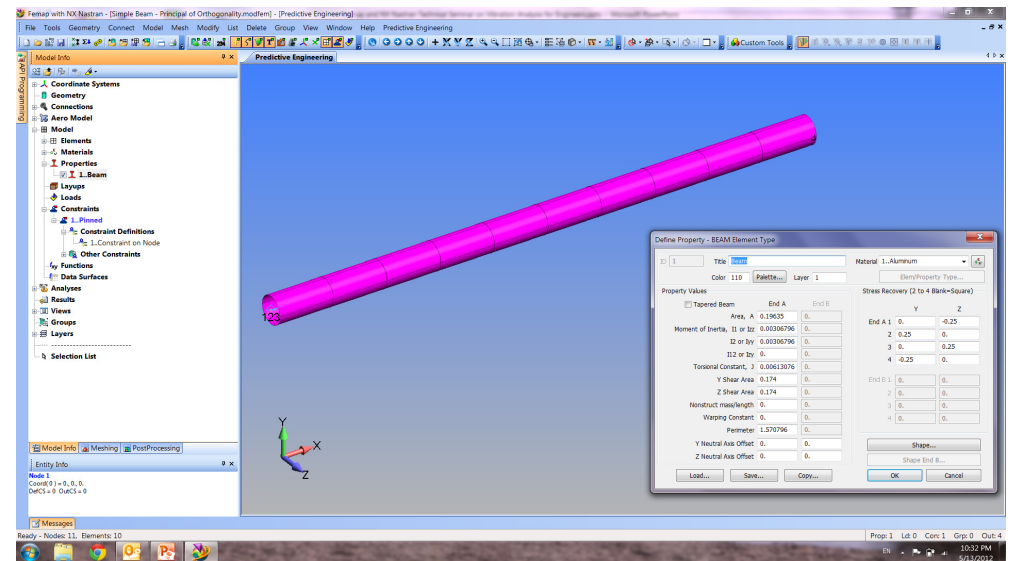

Example Model: Simple Beam - Principal of Orthogonality.modfem
 Analyze | Change B.C.'s | Double Modes

Normal Modes / Eigenvalue problem: Strain Energy Density

- To improve the dynamic performance it is often as simple as moving the first mode to a higher frequency
- Normal modes is all about stiffness and mass
- Strain energy tells you where to add stiffness

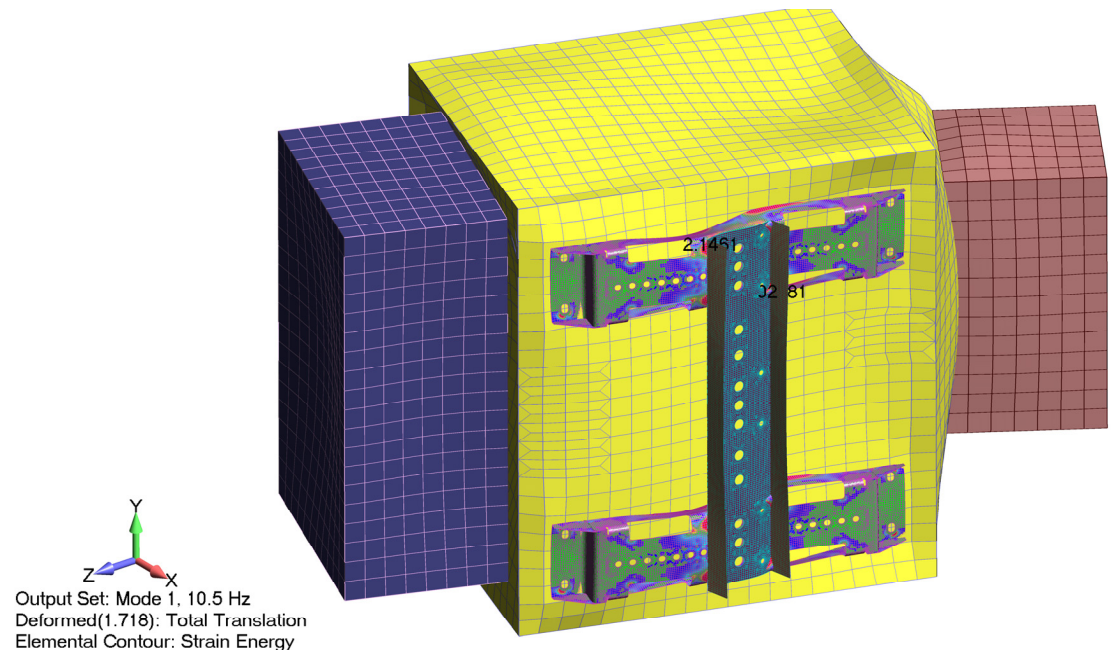

Example Model: Radioframe Networks GR-63-Core
Seismic Analysis.MODFEM
Show Strain Energy | Discuss How Improvements
Were Made | CORE-GR-63 Zone 4 Seismic

Normal Modes / Eigenvalue problem: Mass Participation and Frequency Sweep Analysis

- Mass Participation Tells you what is important
- Expand around significant modes

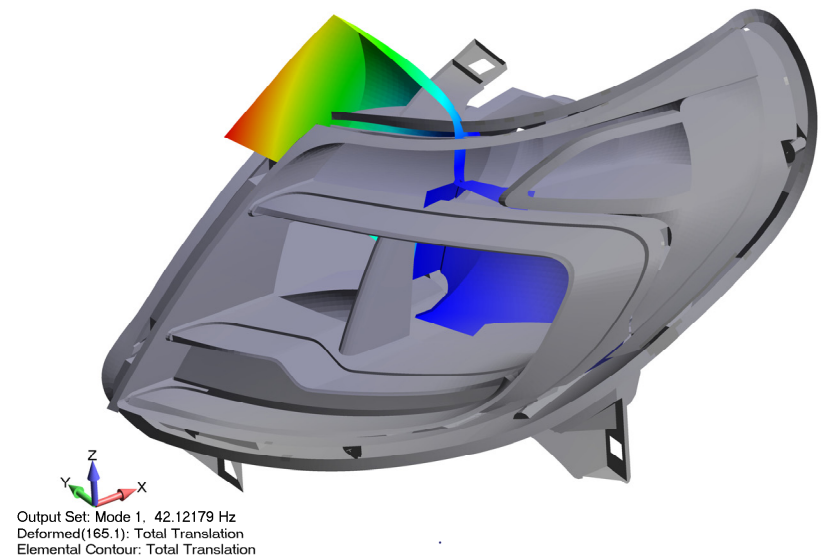
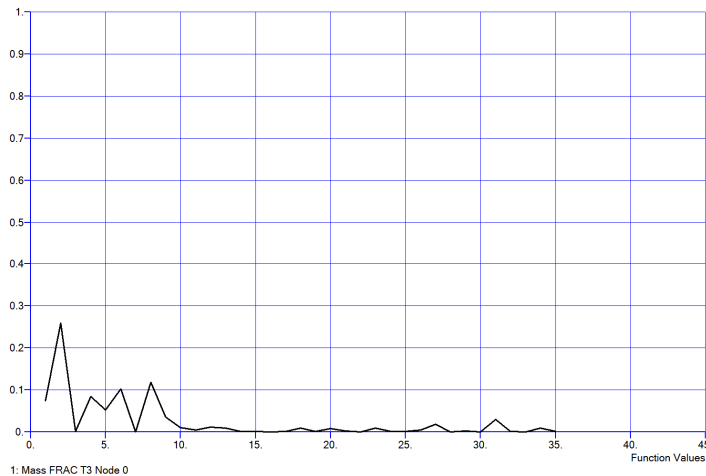

Normal Modes / Eigenvalue problem: Mass Participation and Optimization

- Mass Participation Tells You Heaps
- Optimization is often best done by intelligent inspection
- Don't expect miracles from computer programs

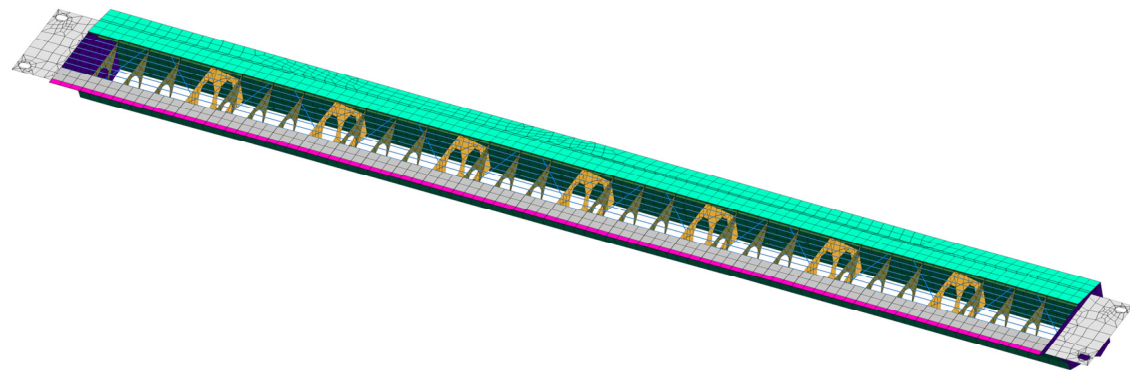

Example Model: Coors Tek Paper Mill Forming Board - Original Design - Start.modfem

Normal Modes / Eigenvalue problem: TOSCA Optimization

- Femap Optimization for Vibration

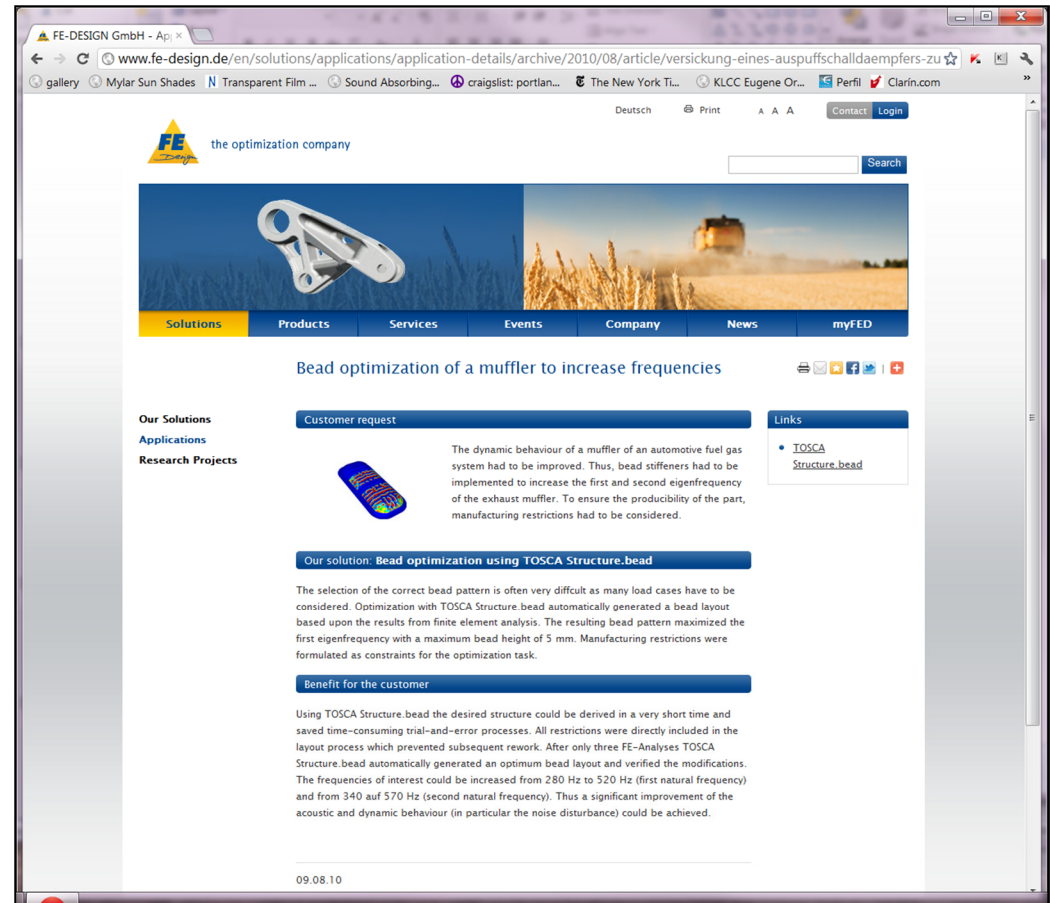

Normal Modes / Eigenvalue problem: Resources

- NX Nastran Documentation
- Predictive Engineering Website
- Be Inquisitive – we have lots of expertise to leverage

