

Linear and Nonlinear Buckling Analysis and Flange Crippling

Engineering Mechanics White Paper



Predictive Engineering, Inc.
2505 SE 11th, Suite 310
Portland Oregon 97202
PH: 503.206.5571 FX: 866.215.1220
www.predictiveengineering.com



Table of Contents

1. Summary5

 1.1 SUMMARY OF BUCKLING MECHANISMS 5

 1.2 ANALYST RECOMMENDATIONS 5

2. Introduction6

3. Everbodys’ First Buckling Analysis Model6

 3.1 CLASSICAL COLUMN BUCKLING 6

 3.2 THE IMPORTANCE OF BUCKLING BOUNDARY CONDITIONS 7

 3.3 ANALYSIS SET DEFINITION FOR BUCKLING 8

 3.4 EIGENVALUE BUCKLING THEORY (THE SHORTEST VERSION YOU’LL EVER SEE)..... 9

 3.5 INTERPRETATION OF EIGENVALUE BUCKLING RESULTS..... 11

4. Geometric Nonlinear analysis of simple column13

 4.1 GEOMETRIC NONLINEAR BUCKLING ANALYSIS SETUP 13

 4.2 ADDITIONAL EXAMPLES OF GEOMETRIC NONLINEAR BUCKLING..... 14

5. Advanced Eigenvalue and Nonlinear Buckling16

 5.1 EIGENVALUE AND GEOMETRIC NONLINEAR BEER CAN BUCKLING..... 16

 5.2 PERTURBATION OF PERFECT GEOMETRY WITH EIGENMODE SHAPE 17

 5.3 BOUNDARY CONDITION SENSITIVITY IN BUCKLING ANALYSIS..... 18

 5.4 BUCKLING ANALYSIS MESH SENSITIVITY 19

 5.5 NONLINEAR MATERIAL ASSESSMENT IN BUCKLING ANALYSIS 21

 5.6 MONTE CARLO GEOMETRIC PERTURBATION 25

 5.7 ANALYST COMMENTARY 26

6. Flange Crippling26

7. Buckling Analysis of Deep-Diving, Eight Passenger Submarine.....26

8. What We Do at Predictive Engineering29

List of Figures

Figure 1: Schematic of classical column buckling.	6
Figure 2: Foundation equations for column buckling.....	7
Figure 3: Boundary conditions used on FEA beam model for column buckling.....	8
Figure 4: The analysis result is shown on the left for the Eigenmode buckled shape.....	9
Figure 5: The Eigenvalue buckling approach returns two output sets. The first output set is NX Nastran Case 1 is a linear analysis.	11
Figure 6: The first Eigenmode is shown deflected with a $\lambda = 5.751$	12
Figure 7: The same column model is leveraged with a change of analysis setup.	13
Figure 8: The vertical deflection is plotted as a function of load. The close-up view shows the results from the Arc-Length analysis method.	14
Figure 9: Example of complex nonlinear geometric buckling from the NX Nastran Nonlinear Handbook.	15
Figure 10: The buckling FEA model is shown above. The buckled mode is very sensitive to end conditions.....	16
Figure 11: The Eigenvalue solution is shown on the left and that for the geometric nonlinear solution on the right.....	17
Figure 12: The Eigenmode deformation is scaled by 0.001 and used to update the nodal positions. A geometric nonlinear analysis is then performed and shown to correlate within 2%.	18
Figure 13: If the end conditions are pinned (think beer can lid), the buckled shape changes.	19
Figure 14: When the cylinder is re-meshed, a new buckled mode shape appears and the buckled load drops by 20% as compared to the more coarsely meshed cylinder shown in Figure 13.	20
Figure 15: Analytical solution for cylinder with pinned ends.	20
Figure 16: As the buckling instability load is approached, a geometric nonlinear analysis will indicate the on-set of instability by a notable jump in the stresses. Note: Deflections shown above have been scaled by 100x. The actual deflection prior to buckling instability is imperceptible.	21
Figure 17: LS-DYNA model within Femap. All analysis parameters were set within Femap.....	22
Figure 18: LS-DYNA analysis results indicate good agreement with the NX Nastran results where material nonlinearity was not considered.....	23



Figure 19: The above plot shows that the cylinder buckles at around 0.0165 or 165 lbf (the LS-DYNA analysis applies full load at 0.1 second). The three elements are located equidistant along the vertical length of the cylinder..... 24

Figure 20: This sequence of images shows how buckling progresses in a completely nonlinear analysis..... 25

Figure 21: With the beer can slightly perturbed, the buckling load drops by 40% 25

Figure 22: An experimental chart is used to determine the crippling load pressure (F_{cr}) of a flange section. The crippling load is the average compressive stress across the flange..... 27

Figure 23: A simple supported beam is given an evenly distributed load across its top flange. The yield stress of the material is 38,000 psi (2024-T3 from Figure 22). A static analysis shows no problems but a buckling analysis indicates it would fail at 0.17x of the applied load. 28

Figure 24: A simply supported I-Beam structure is shown above at its crippling load point..... 28

Figure 25: Deep-diving, eight passenger luxury submarine. The FEA work was validated against strain gauged data. The full report on this work can be seen at www.PredictiveEngineering.com..... 30

Figure 26: The NX Nastran Eigenvalue buckling analysis predicts a buckling factor of 2.6..... 31

1. SUMMARY

1.1 SUMMARY OF BUCKLING MECHANISMS

- ✓ It is driven by compressive forces.
- ✓ It is a geometric nonlinear behavior. As load is applied, the structure deforms and the load path changes in response to this change in geometry.
- ✓ Perfect structures that are loaded with perfectly aligned loads will not buckle in the perfect modeling world.
- ✓ Since buckling behavior is driven by structural deformation, it can be sensitive to geometric irregularities and mesh density.
- ✓ Buckling is generally an elastic behavior (geometric instability).

1.2 ANALYST RECOMMENDATIONS

- 👍 Run model through both Eigenvalue buckling and geometric nonlinear buckling analyses. Compare results for consistent behavior. Check to see if material's elastic limit has been exceeded.
- 👍 Tweak geometry:
 - Perturb geometry using Eigenvalue buckling mode shape.
 - Add geometric eccentricities, e.g., offset straight beams by "Length_of_Beam/500".
 - Use LS-DYNA *PERTURBATION to introduce Monte Carlo random geometric distortion.
- 👍 Investigate mesh convergence given recommendation of five elements per half-sine wave of buckled mode. This is classical mechanics.
- 👍 Determine stress state prior to buckling and assure that the stress is no more than 80% of the yield stress of the material. This step will ensure that your analysis results are relevant for linear elastic buckling theory.
- 👍 If the buckling stress exceeds the yield strength of the material, material plasticity must be addressed in the analysis procedure.
- 👍 Check for flange crippling. If many sections exist in your model, create spreadsheet with tabulated values of b/t and their respective F_{cr} values for the load cases used in the model.
- 👍 Mission critical structures subjected to high compressive loads should be carefully analyzed using both Eigenvalue and nonlinear geometric analysis. Additionally, the meshed geometry should be "perturbed" in a random manner to ensure all possible buckling modes are captured.

2. INTRODUCTION

This white paper will walk you through the NX Nastran Buckling Analysis techniques and show you how to validate your linear buckling analysis with a non-linear static analysis. Additional examples are presented on flange crippling and then finally the application of these techniques to the buckling analysis of an eight-passenger, deep-diving luxury submarine.

3. EVERYBODY'S' FIRST BUCKLING ANALYSIS MODEL

3.1 CLASSICAL COLUMN BUCKLING

Calculating the buckling force for an ideal column is quite simple. As long as you know the length, second moment of inertia and elastic modulus of the beam, you can calculate the force by hand. Figure 1 shows the setup for this example.

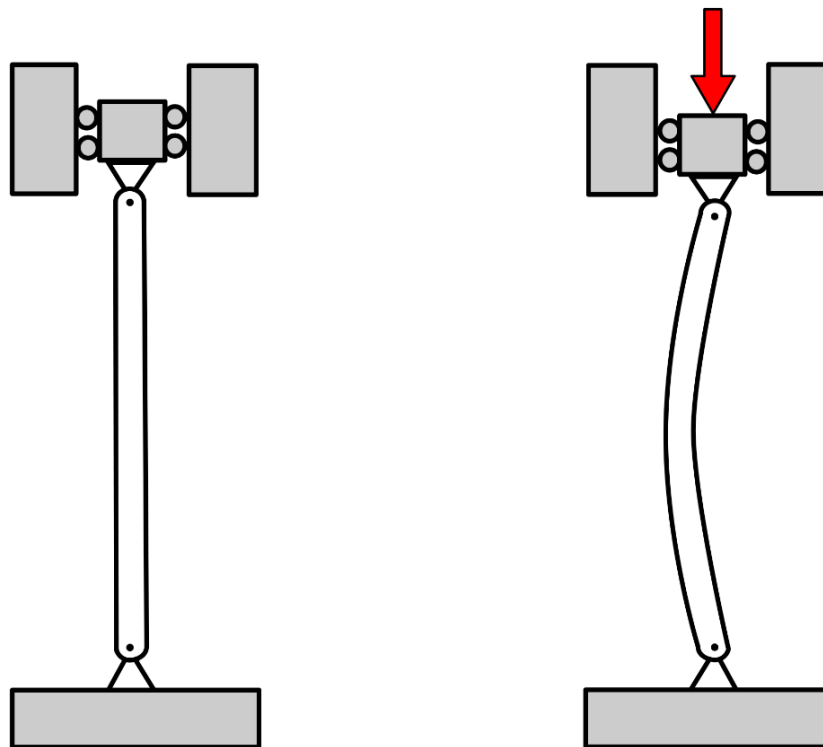
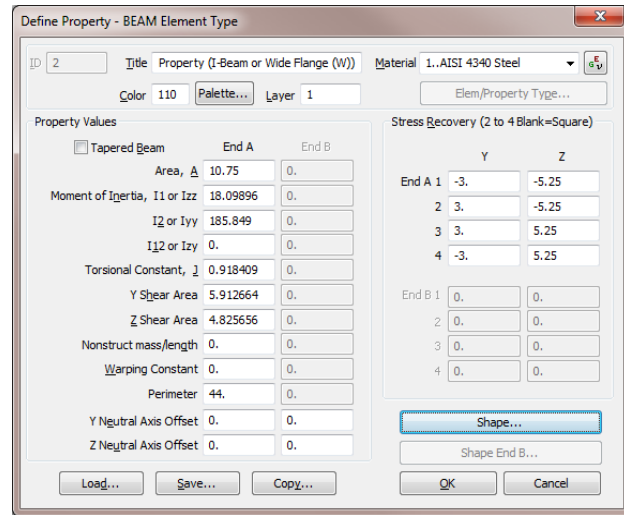
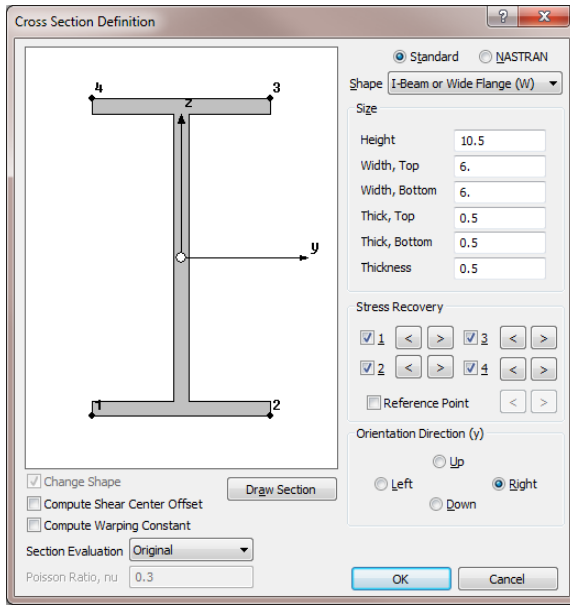

Figure 1: Schematic of classical column buckling.



$$F = \frac{\pi^2 EI}{(KL)^2} = \frac{\pi^2 (2.9e7 \text{psi} * 18.1 \text{in}^4)}{(1 * 300 \text{in})^2} = 57,562 \text{ lbf}$$

Figure 2: Foundation equations for column buckling.

The cross-section properties and equations given above provide all the necessary ingredients to calculate the buckling load of the column. The factor “K” shown above is used to classify the beam’s end conditions (Manual of Steel Construction, 8th edition, American Institute of Steel Construction). The buckling load depends upon whether the beam’s end points are fixed, pinned or partially constrained.

However the problem with this sophomoric example is that it doesn’t provide enough engineering depth to provide a more robust understanding of how the mechanics of buckling works.

3.2 THE IMPORTANCE OF BUCKLING BOUNDARY CONDITIONS

Figure 3 shows how the beam, given schematically in Figure 1, is configured in the FEA world. The beam is pinned at both ends. The vertical degree of freedom is released at the upper constraint. Rotation about the vertical axis is prevented at the lower constraint. An arbitrary load is then applied to the upper-most node.

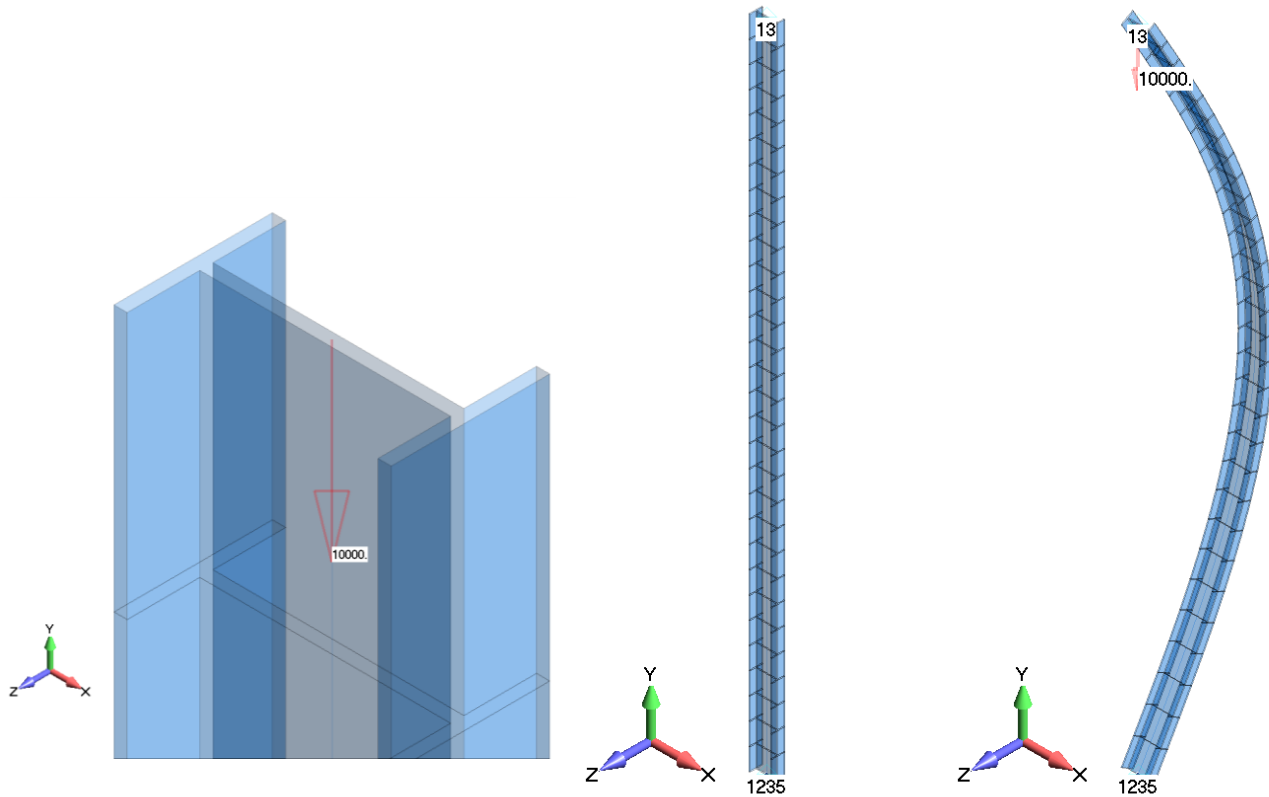

Figure 3: Boundary conditions used on FEA beam model for column buckling.

3.3 ANALYSIS SET DEFINITION FOR BUCKLING

The analysis setup for linear, eigenvalue buckling is quite simple and additional guidance can be found in the NX Nastran User guide. Figure 4 provides a graphical representation of the important picks for this analysis.

As shown in the analysis set legend (lower left-hand text of the graphical image in Figure 4), the title of the Output Set will include a load factor value. This factor multiplied by the applied load is equal to the critical load. $5.751 \times 10,000 \text{ lbf} = 57,510 \text{ lbf}$, correlating to the hand calculation of 57,562 within 0.1%. One should note that the Eigenmode deformation is meaningless as is the eigenmode deformation magnitude is in a normal modes analysis. In this case for the column, a unity value of 1.0 is provided from the NX Nastran analysis.

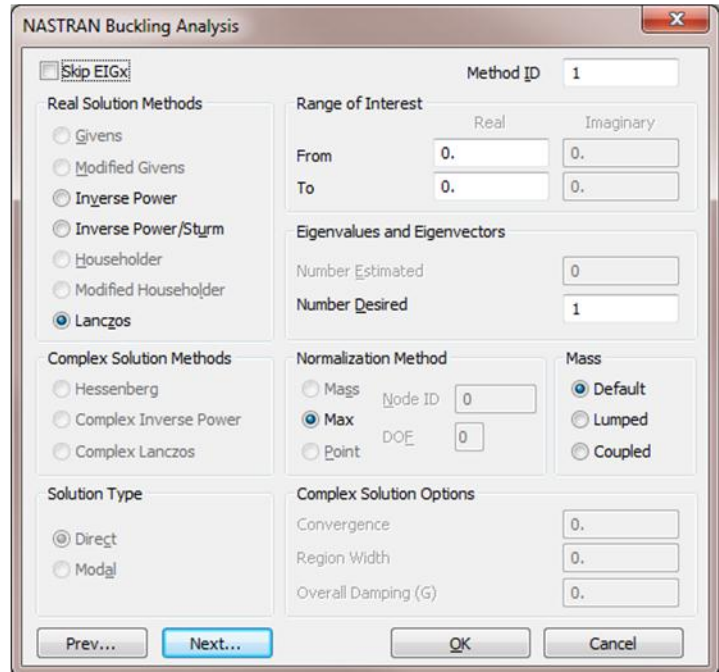
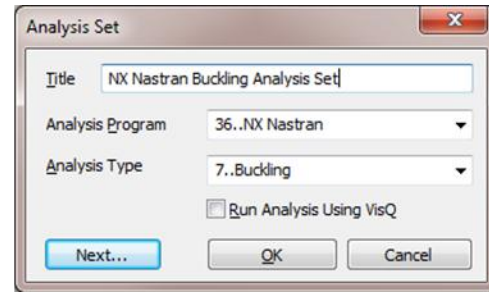
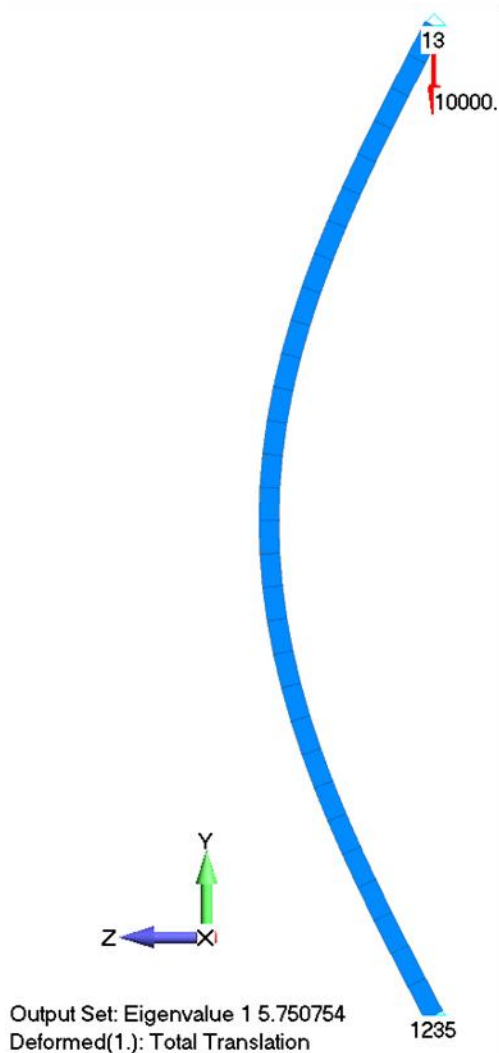

Figure 4: The analysis result is shown on the left for the Eigenmode buckled shape.

3.4 EIGENVALUE BUCKLING THEORY (THE SHORTEST VERSION YOU’LL EVER SEE)

Since a white paper wouldn’t be complete without some equations, a bit of background is given. The analysis starts with forming the differential stiffness matrix for the structure. In general FEA, the first order stiffness matrix is only used. This formulation assumes, e.g., that $\sin(\theta) = \theta$. It is a small displacement formulation. The differential stiffness matrix assumes large displacement and takes into account “stiffening” or “weakening” effects with the geometry experiences large deformation. What is large deformation? A simple answer is not easy to give and “rules-of-thumb” often lead to embarrassing traps. The best approach is to use your intuition and explore a bit with simple models. It is somewhat intuitive that as a column is heavily loaded and starts to bow, its load carrying capacity becomes greatly compromised. This is your clue.

Mathematically, one can look at the NX Nastran User Guide or any number of mechanics textbooks to see the mathematical foundation. But let's do a really brief tour to see how the Eigenvalue formulation is developed.

$$[K] = [K_a] + [K_d]$$

Equation 1: The total stiffness of the system is a combination of the linear stiffness $[K_a]$ matrix and the differential stiffness matrix $[K_d]$.

$$[U] = 0.5 \{u\}^T [K_a] \{u\} + 0.5 \{u\}^T [K_d] \{u\}$$

Equation 2: The energy of the system can be written above. This is a standard FEA approach since once you have the energy equation, it can be differentiated to arrive at an equilibrium point.

$$\frac{\partial [U]}{\partial u_i} = [K_a] \{u\} + [K_d] \{u\} = \{0\}$$

Equation 3: The energy equation is differentiated and if set to 0.0 defines a point of static equilibrium or maximum load carry capacity since the structure is at its tipping point.

$$[[K_a] + P_a [\bar{K}_d]] \{u\} = \{0\}$$

Equation 4: The prior equation 3 can be rewritten in this other form (don't ask me how...but I'm sure it can be done).

$$P_{cr_i} = \lambda_i \cdot P_a$$

Equation 5: This substitution shows how the buckling load factor (λ) is used in the analysis against the applied load (P_a) used in the analysis.

$$|[K_a] + \lambda_i[K_d]| = [0]$$

Equation 6: At this point we have the Eigenvalue equation which can be readily solved for its roots and its mode shapes. Since a buckling analysis is typically only concerned with the first sign of collapse, the analysis stops at the first mode.

3.5 INTERPRETATION OF EIGENVALUE BUCKLING RESULTS

Figure 5 and Figure 6 show the two output sets generated from the analysis run. The first set (Figure 5) is the linear static result of the applied load. The second set (Figure 6) is the Eigenvalue buckling result and provides the λ load factor as given in Equation 5: This substitution shows how the buckling load factor (λ) is used in the analysis against the applied load (P_a) used in the analysis.

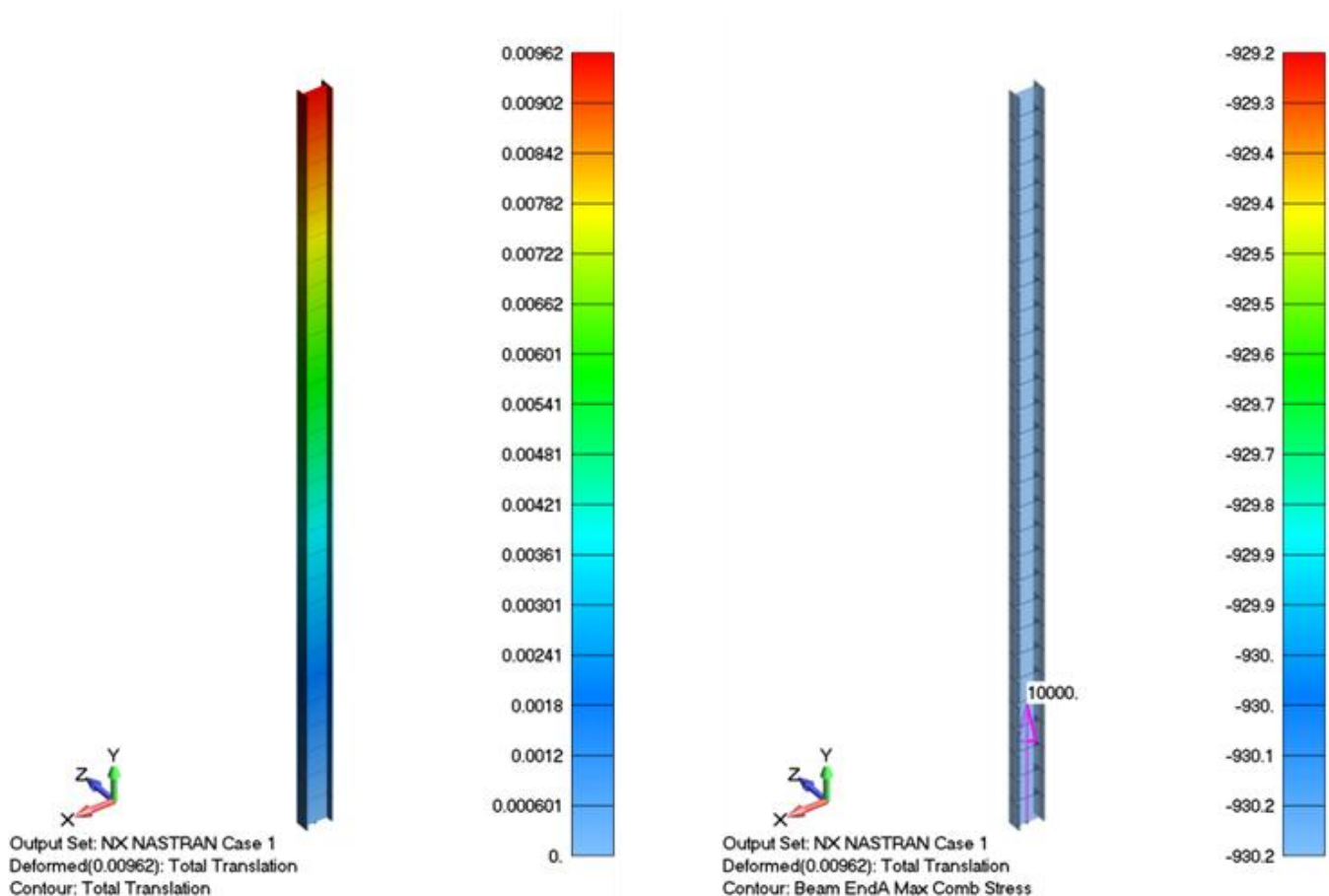

Figure 5: The Eigenvalue buckling approach returns two output sets. The first output set is NX Nastran Case 1 is a linear analysis.

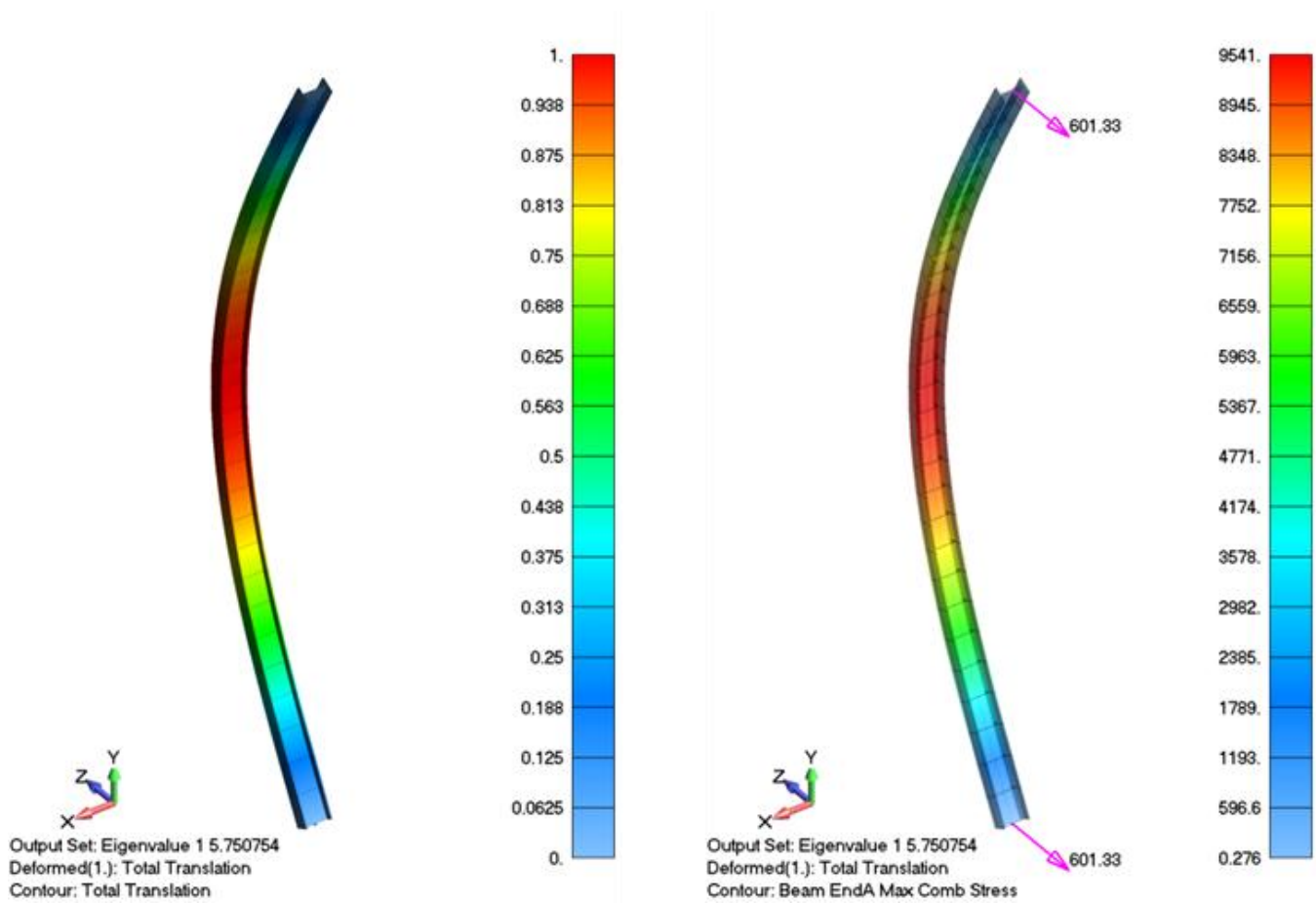

Figure 6: The first Eigenmode is shown deflected with a $\lambda = 5.751$.

The peak deflection is meaningless and is given at a unit value of 1.0. Likewise the stresses generated from the Eigenmode analysis are not significant. It should be noted, as with the equations given in the prior section, only the critical load is predicted.

This limitation with the Eigenvalue buckling approach indicates the often time requirement for a more thorough investigation.

4. GEOMETRIC NONLINEAR ANALYSIS OF SIMPLE COLUMN

A geometric nonlinear solution, as the name implies, only looks at the effects of large deformation on the FEA model and ignores all material nonlinearities. The general approach is that the regular and differential stiffness matrices are generated and the solution is solved in an incremental approach. That is, as load is applied and the structure deforms, the stiffness matrix is reformed to account for the deformation within individual elements. This is a robust approach and captures all of the relevant physics of the buckling approach except for that of material instability. However, we'll show how to address material nonlinearity within a geometry buckling analysis and determine whether the analysis must include this extra nonlinearity or not.

4.1 GEOMETRIC NONLINEAR BUCKLING ANALYSIS SETUP

Femap provides a simple way to setup up a NX Nastran nonlinear analysis. Figure 7 shows the major cards. The analysis is told to solve within 10 time steps. In NX Nastran format, time equals 1.0 is the maximum applied load. The analysis is shown to diverge at a time step of 0.5755 and would translate into a total applied load of 57,550 lbf. This result correlates well with the Eigenvalue buckling result of 57,510 lbf.

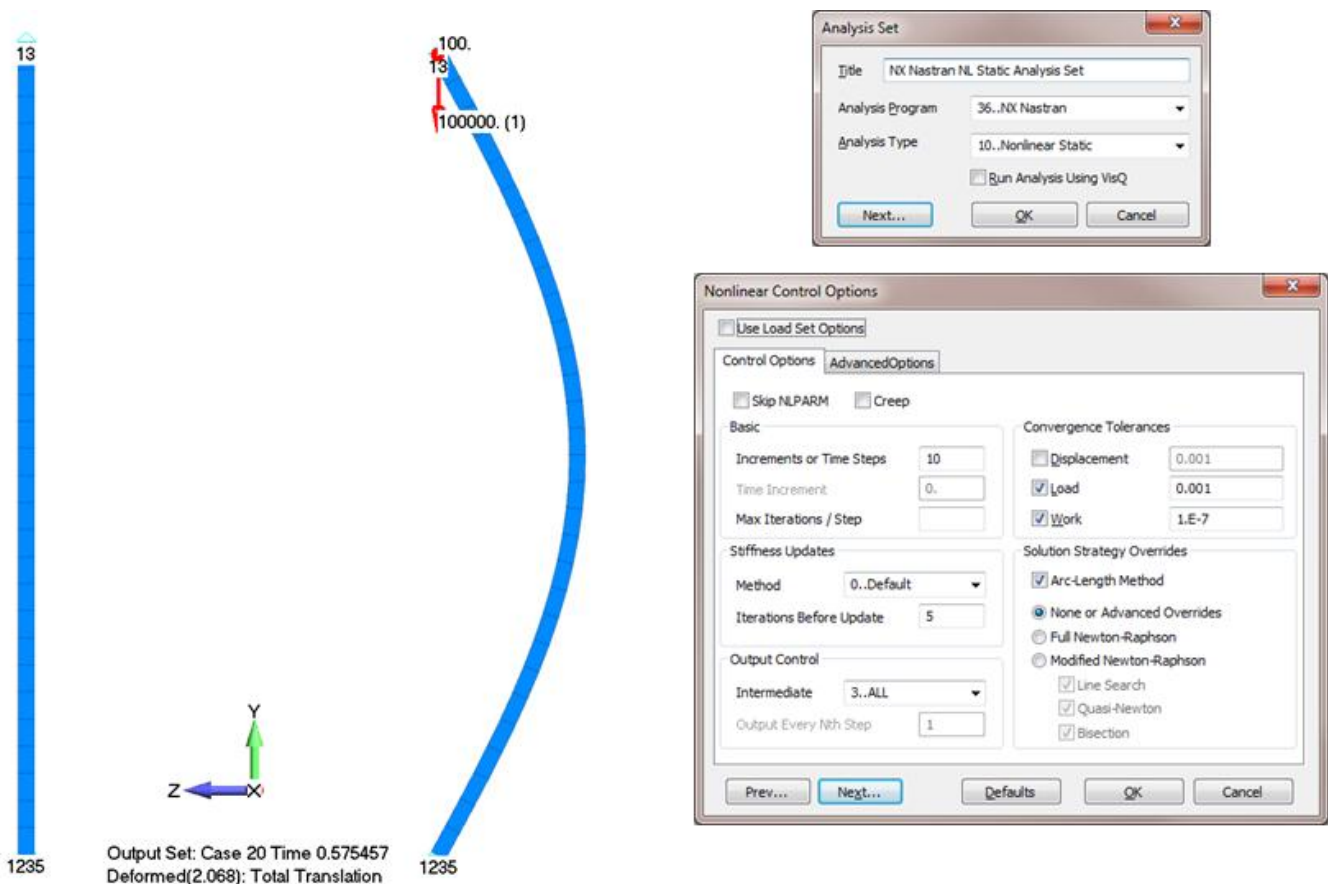

Figure 7: The same column model is leveraged with a change of analysis setup.

If this analysis is refined a bit by turning on the Arc-Length method (non-standard in the nonlinear setup), one can see how the column would behave as it snaps through. These results are shown in Figure 8.

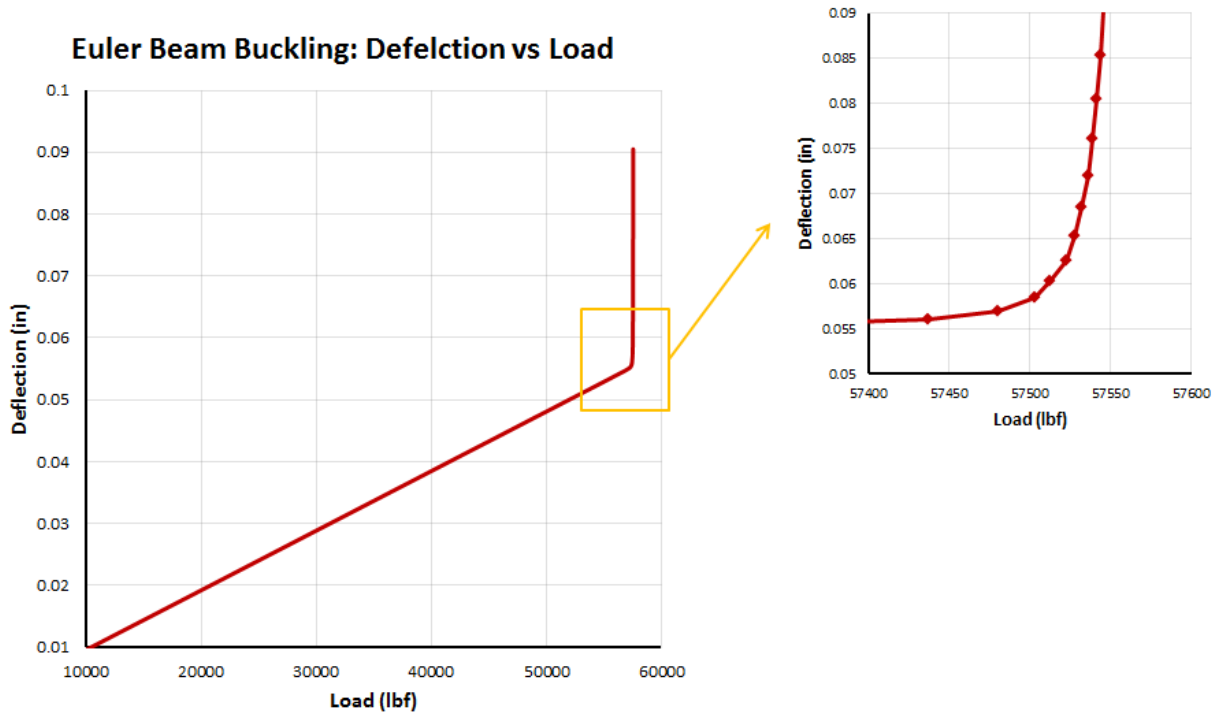

Figure 8: The vertical deflection is plotted as a function of load. The close-up view shows the results from the Arc-Length analysis method.

4.2 ADDITIONAL EXAMPLES OF GEOMETRIC NONLINEAR BUCKLING

The NX Nastran Handbook of Nonlinear Analysis provides an interesting reference to a more complex buckling analysis along with some experimental results. This example is shown in Figure 9.

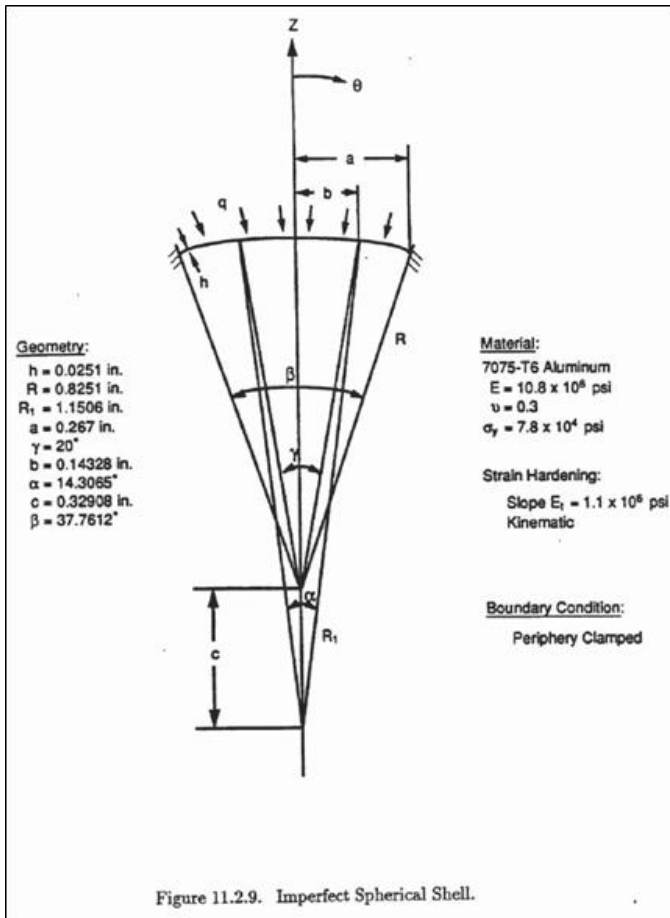

Figure 11.2.9. Imperfect Spherical Shell.

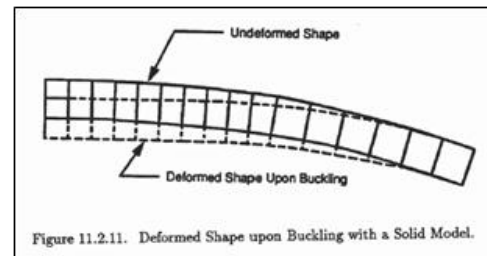
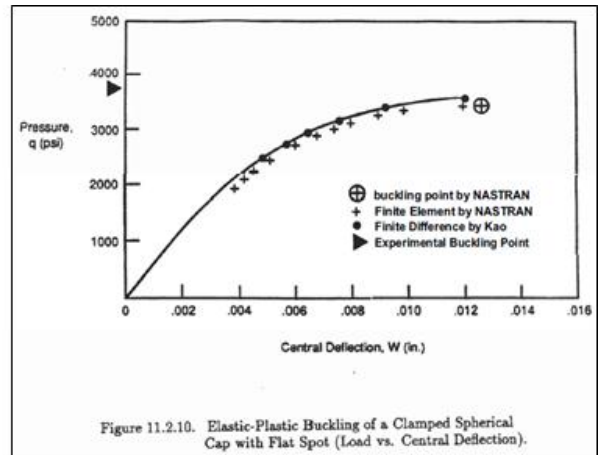

Figure 9: Example of complex nonlinear geometric buckling from the NX Nastran Nonlinear Handbook.

5. ADVANCED EIGENVALUE AND NONLINEAR BUCKLING

A more advanced example of linear and nonlinear buckling is provided here. A simple thin walled aluminum cylinder (i.e. beer can) is modeled with plate elements. The load case is an equally distributed axial force. The beer can is carefully constrained to avoid end effects.

The reason why this example was chosen is that it presents several nice buckling modeling challenges and good examples such as these are very difficult to find. Which leads to the phrase: “Elegant simplicity is deceptively difficult to achieve.”

5.1 EIGENVALUE AND GEOMETRIC NONLINEAR BEER CAN BUCKLING

Figure 10 shows our starting point for this analysis work. The end conditions were defined to mimic a perfect cylinder sitting on top of a perfectly frictionless counter top. A perfectly aligned axial load was applied to the top edge of the cylinder of 1,000 lbf.

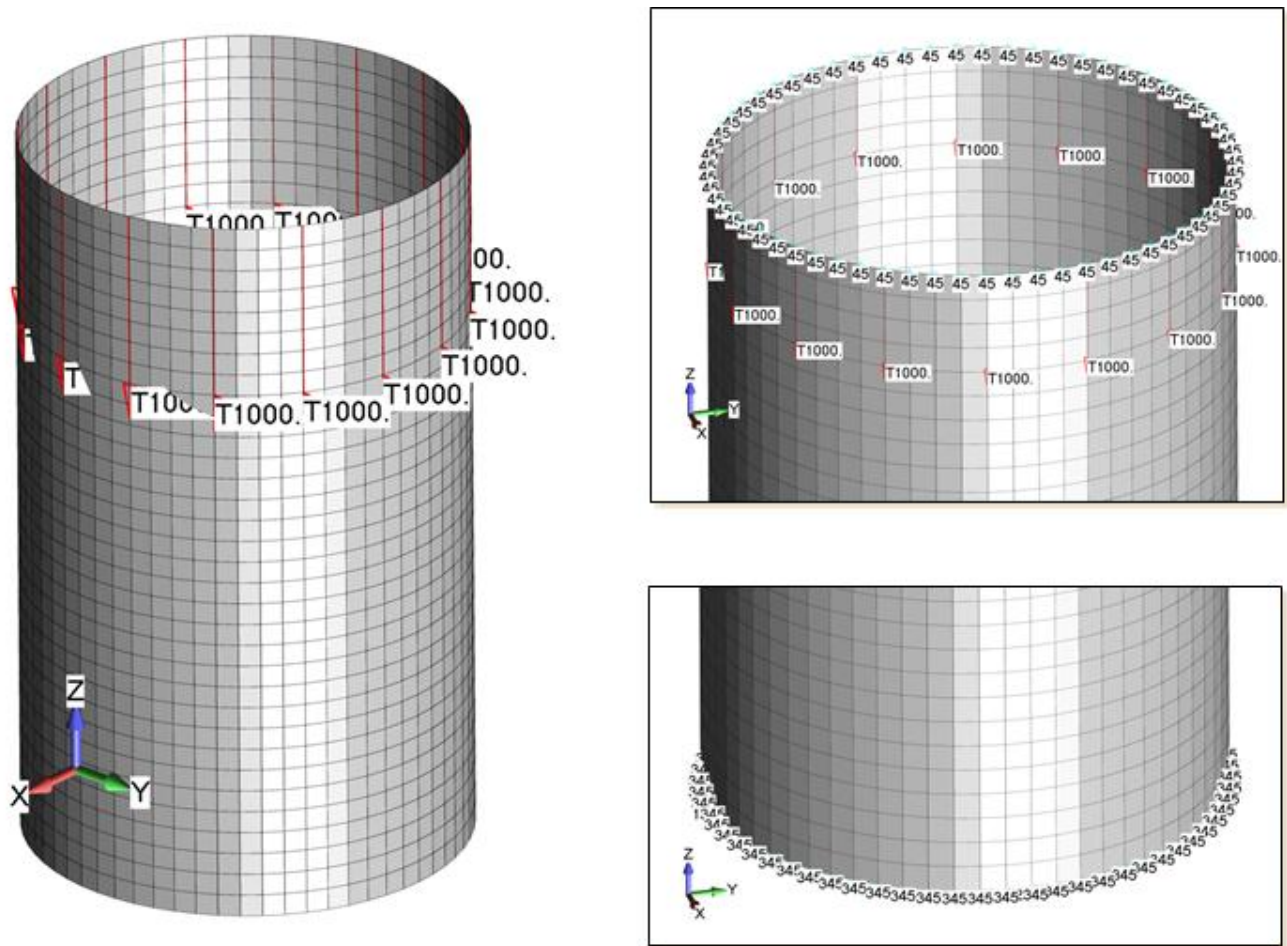
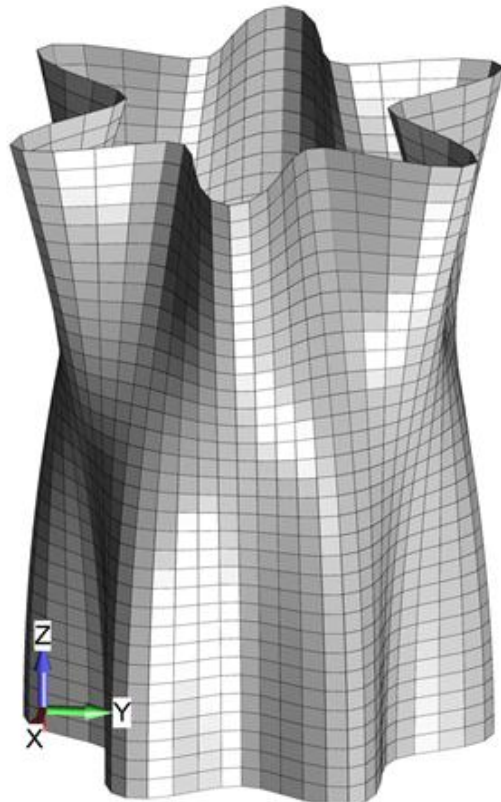
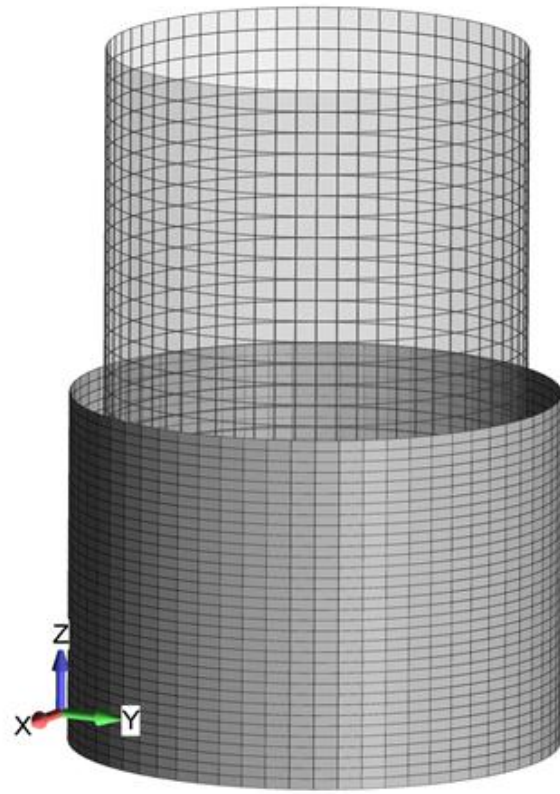

Figure 10: The buckling FEA model is shown above. The buckled mode is very sensitive to end conditions.

With a perfect cylinder, the Eigenvalue buckling solution indicates that the cylinder should buckle at a load of 73 lbf (0.073*1,000 lbf). The nonlinear solution just compresses the cylinder. In the perfect numerical world, this makes perfect sense.



Output Set: Eigenvalue 1 0.0729764
Deformed(0.257): Total Translation



Output Set: Geometric Nonlinear Perfect Cylinder
Deformed(0.0249): Total Translation

Figure 11: The Eigenvalue solution is shown on the left and that for the geometric nonlinear solution on the right.

5.2 PERTURBATION OF PERFECT GEOMETRY WITH EIGENMODE SHAPE

A common trick to initiate buckling in perfect geometry (i.e., perfect mesh), is to take the buckled mode shape and map it onto the mesh. This process is shown schematically in Figure 12. This can be done using a Femap API within the **Custom Tools > PostProcessing > Nodes Move By Deform with Options**. We have scaled the mode shape by 0.001. The concept is that you just want to perturb the perfect geometry ever so slightly such that it will correctly start to buckle. It should be noted that the two solutions correlate within 2%.

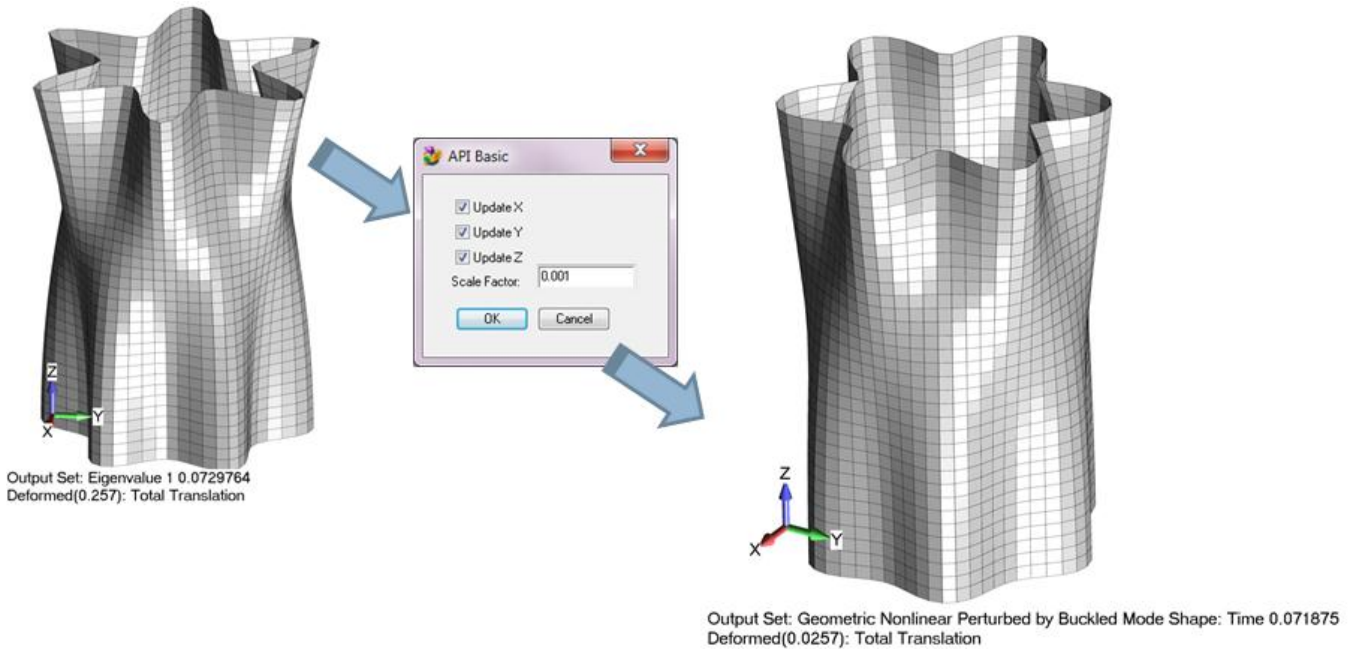

Figure 12: The Eigenmode deformation is scaled by 0.001 and used to update the nodal positions. A geometric nonlinear analysis is then performed and shown to correlate within 2%.

5.3 BOUNDARY CONDITION SENSITIVITY IN BUCKLING ANALYSIS

If we adjust the constraints to restrict horizontal movement on the top edge and to pin the bottom edge, the buckling force increases to around 200 lbf. This result is shown in Figure 13. These constraints simulate a real beer can a bit more closely since the pinned conditions simulated the top and bottom lids of the beer can. At first glance, the 200 lbf buckling load limit seems reasonable for our idealized beer can.

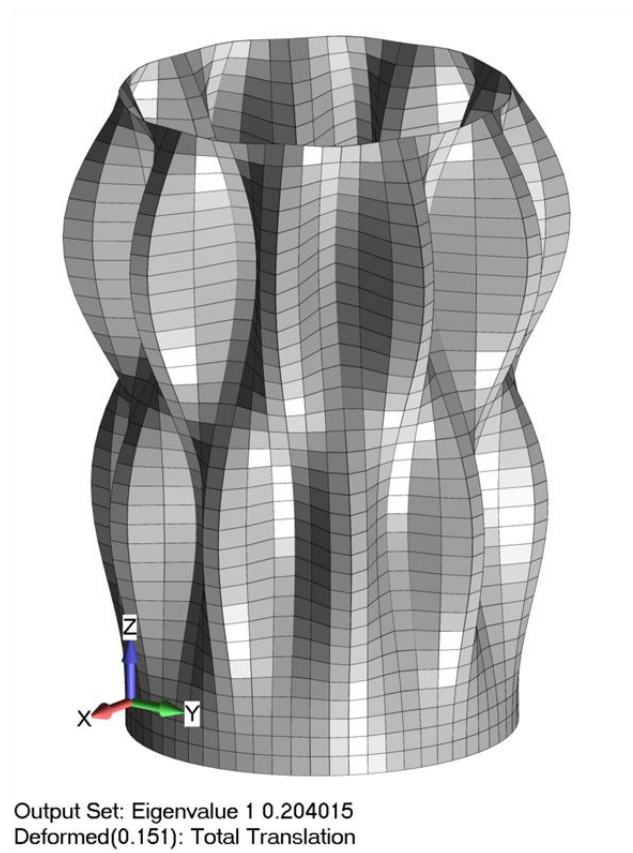
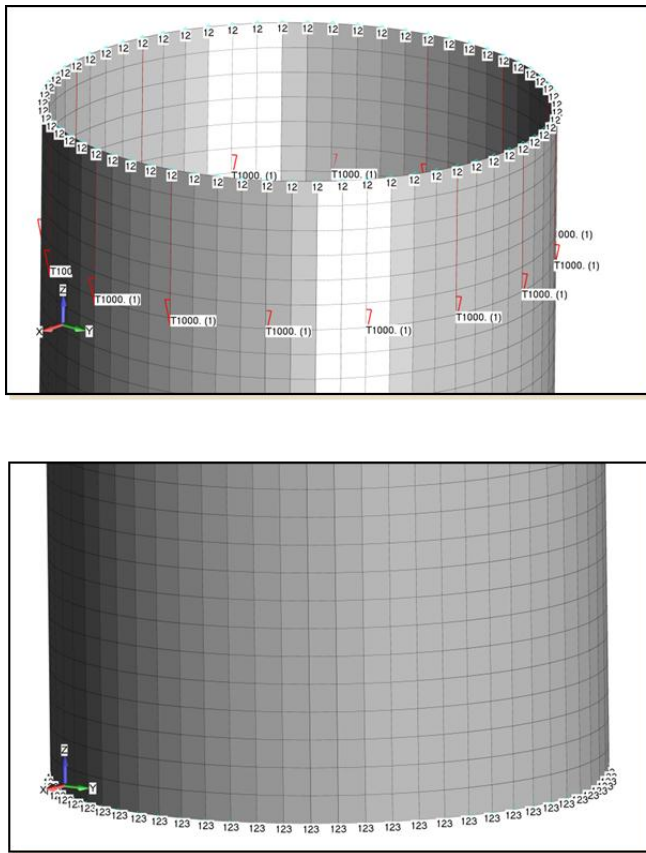

Figure 13: If the end conditions are pinned (think beer can lid), the buckled shape changes.

5.4 BUCKLING ANALYSIS MESH SENSITIVITY

There is only one problem with the prior analysis, it is wrong. How do we know it is wrong? In the NX Nastran User's Guide (User.pdf), Chapter 22.4 Linear Buckling Assumptions and Limitations: "A minimum of five grid points per half sine wave (buckled shape) is recommended." In the prior model it seems to fit this description but what this recommendation is really saying is that buckling behavior can be mesh sensitive and if you are unsure of the result, one should perform a convergence study. In Figure 14, a re-meshed model is shown and the calculated Eigenvalue drops to 0.165. This yields a buckling load of 165 lbf. When compared to the prior, coarser mesh model, the difference is almost 20%.

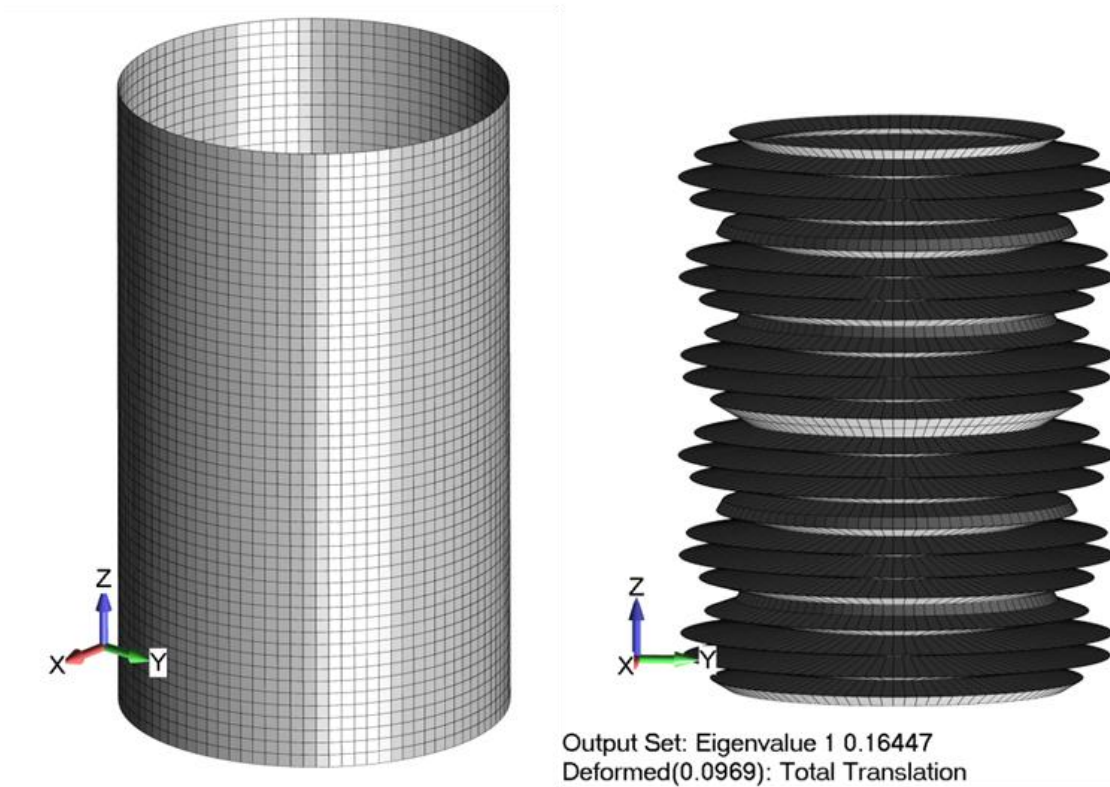

Figure 14: When the cylinder is re-meshed, a new buckled mode shape appears and the buckled load drops by 20% as compared to the more coarsely meshed cylinder shown in Figure 13.

This result was then confirmed using an analytical solution and is shown in Figure 15.

Timoshenko and Gere, Theory of Elastic Stability, 1961 provides the following equation:

$$\text{Wall}_{\text{Cyl}} := 0.002 \cdot \text{in} \quad E_{\text{Al}} := 10.7 \cdot 10^6 \cdot \frac{\text{lbf}}{\text{in}^2} \quad \nu := 0.33$$

$$\text{Radius}_{\text{Cyl}} := 1.5 \cdot \text{in}$$

$$N_x := \frac{E_{\text{Al}} \cdot \text{Wall}_{\text{Cyl}}^2}{\text{Radius}_{\text{Cyl}} \cdot \sqrt{3 \cdot (1 - \nu^2)}}$$

$$P_{\text{cr}} := N_x \cdot 2 \cdot \pi \cdot \text{Radius}_{\text{Cyl}}$$

$$P_{\text{cr}} = 164 \text{ lbf}$$

Figure 15: Analytical solution for cylinder with pinned ends.

5.5 NONLINEAR MATERIAL ASSESSMENT IN BUCKLING ANALYSIS

A nonlinear analysis provides the buckling stress at the point of collapse. The utility of the geometrically nonlinear approach is that one can gain insight into the structure prior to its buckled condition. The image on the left shows the can with a load of 159 lbf while the image on the right shows the buckled condition is at 162 lbf. In this example, if the yield stress of the material was higher than 14,000 psi, it would indicate that the buckling instability was independent of any material nonlinearity. This is a very useful observation and allows the analyst to confidently move forward with their design without any side worries about the possibility of plastic collapse.

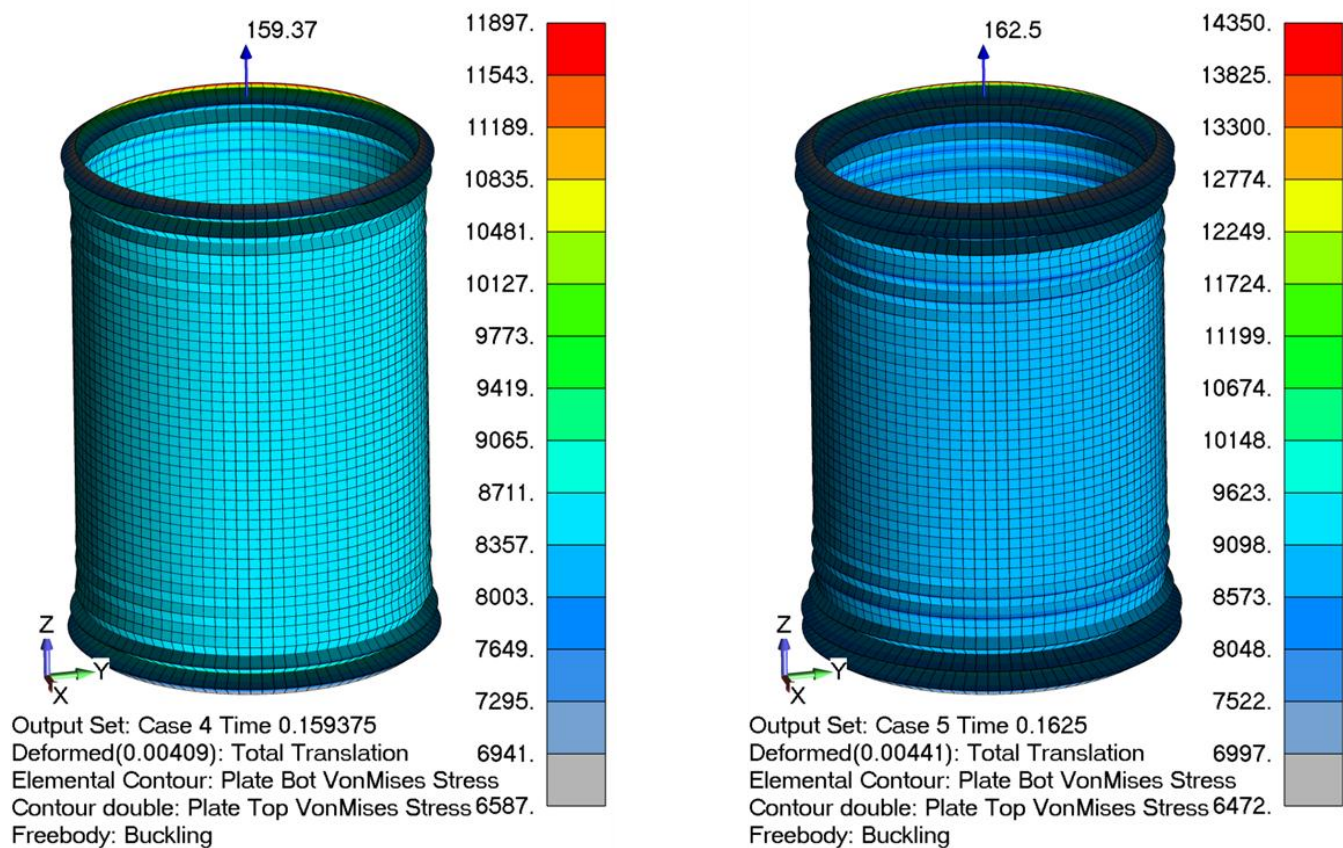

Figure 16: As the buckling instability load is approached, a geometric nonlinear analysis will indicate the on-set of instability by a notable jump in the stresses. Note: Deflections shown above have been scaled by 100x. The actual deflection prior to buckling instability is imperceptible.

Another example uses LS-DYNA as the solver. The model setup is shown in Figure 17 and is directly analyzed with LS-DYNA from the Femap environment. In this solution sequence, the aluminum cylinder is given a yield stress of 40,000 psi.

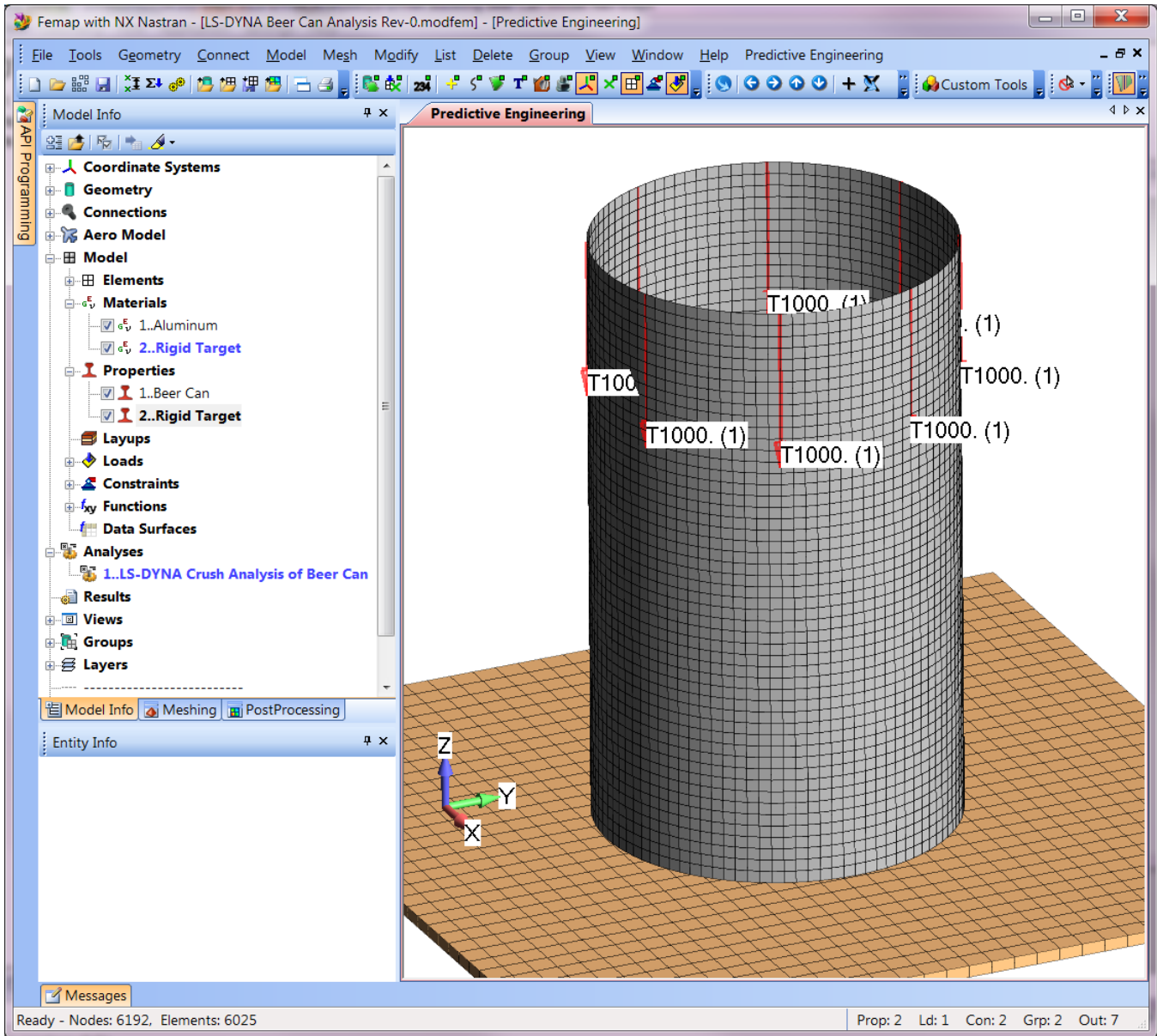

Figure 17: LS-DYNA model within Femap. All analysis parameters were set within Femap.

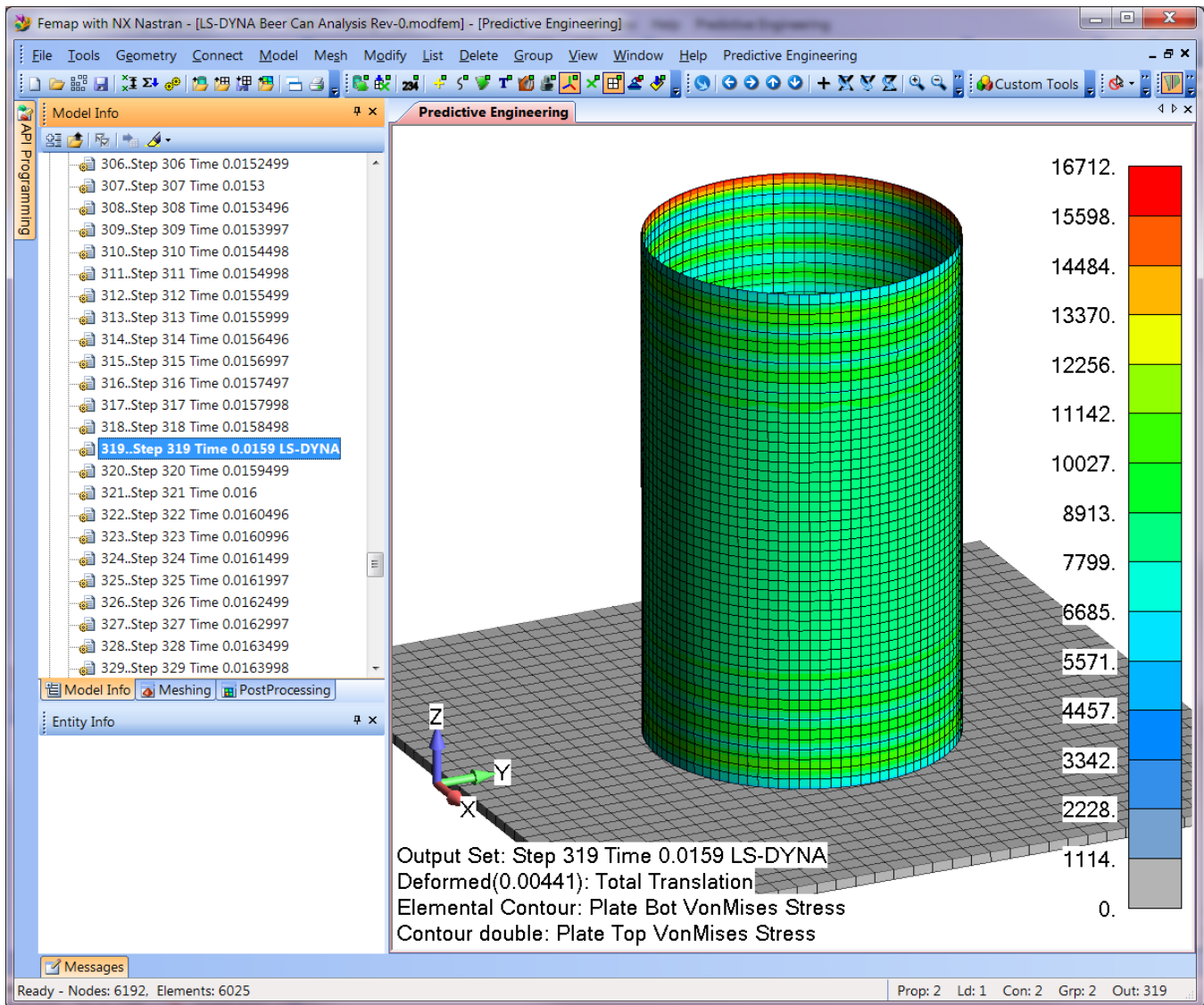
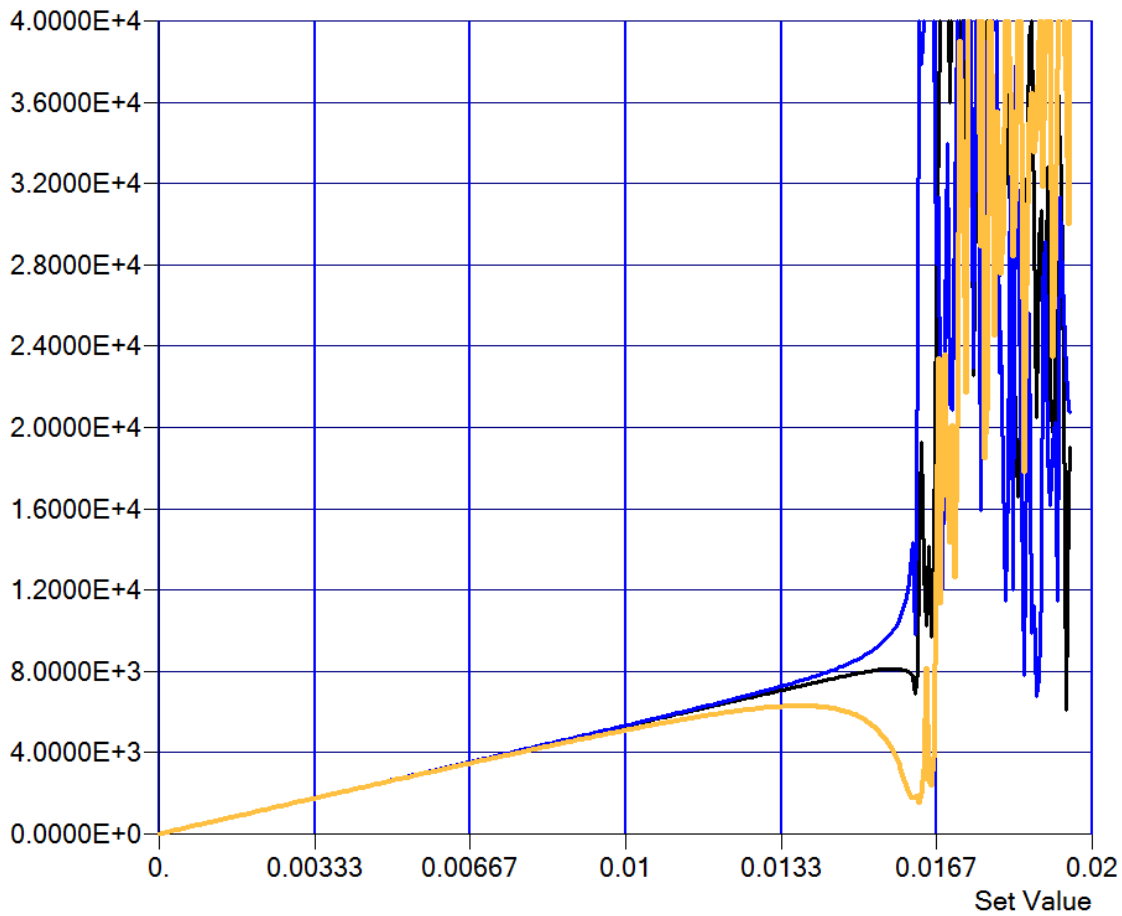

Figure 18: LS-DYNA analysis results indicate good agreement with the NX Nastran results where material nonlinearity was not considered.



- 1: Plate Top VonMises Stress, Element 1719
- 2: Plate Top VonMises Stress, Element 1559
- 3: Plate Bot VonMises Stress, Element 1545

Figure 19: The above plot shows that the cylinder buckles at around 0.0165 or 165 lbf (the LS-DYNA analysis applies full load at 0.1 second). The three elements are located equidistant along the vertical length of the cylinder.

Figure 19 shows that the buckling behavior of the cylinder is completely independent of any material nonlinearity since its behavior is linear up to the point of its collapse.

The completely nonlinear analysis procedure is shown in Figure 20 as the beer can is allowed to completely collapse.

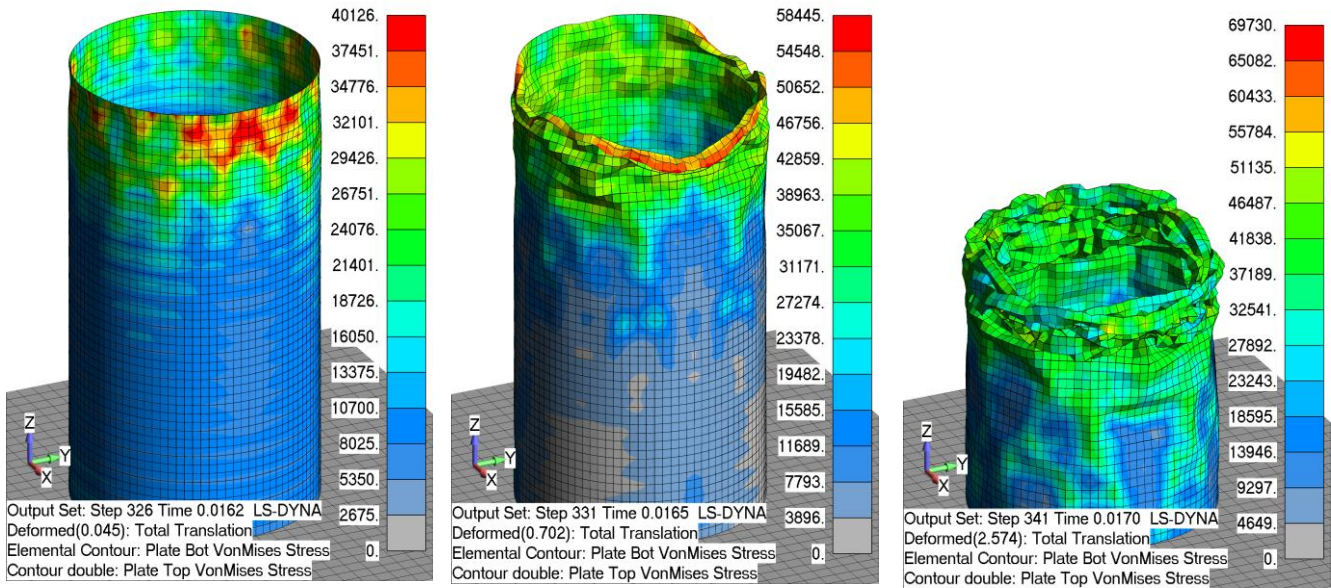

Figure 20: This sequence of images shows how buckling progresses in a completely nonlinear analysis.

5.6 MONTE CARLO GEOMETRIC PERTURBATION

In this example, the nodes of the can were tweaked, or perturbed, to create a completely random surface. This operation was done within LS-DYNA and allows one to specify a completely random displacement of the nodes. Results shown in Figure 21 indicate that the can would buckle right around 97 lbf.

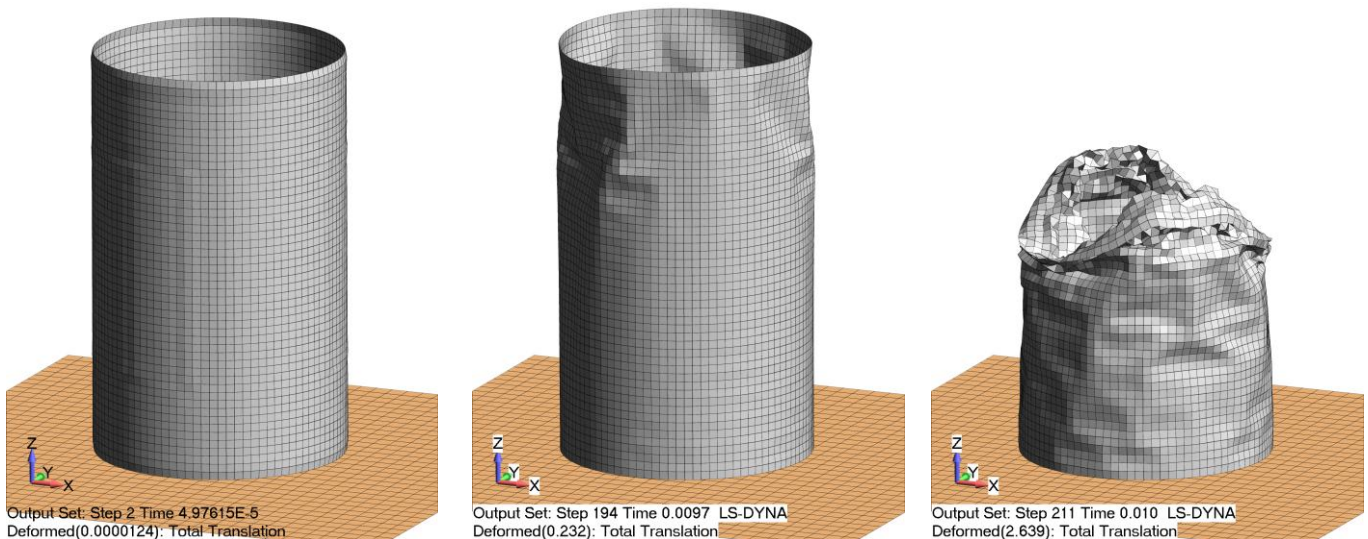

Figure 21: With the beer can slightly perturbed, the buckling load drops by 40%

In the first image, on the far left in Figure 21, very small ripples can be seen in the beer can. These small ripples represent the very small perturbation of the can's original geometry. With only these slight modifications, the buckling load changed significantly. This result indicates that even given a theoretical calculation of 164 lbf, a more engineering appropriate buckling load would be 95 lbf given the possibility of very real manufacturing defects in the structure. This lower load also is a bit more realistic given that many of us have most likely tried to stand on a beer can at one time or another and noted the difficulty of getting the can to support our weight.

5.7 ANALYST COMMENTARY ON THE BUCKLING OF VERY THIN STRUCTURES

It should be mentioned that this example is a bit forced. That is, the reason that the beer can is so extremely sensitive to perturbation is that the wall of the can is very thin at 0.002". Hence, it provides a very stark example about the sensitivities of boundary conditions, mesh and perturbation. One can imagine that in more typical engineering structures there isn't quite as much of drama.

6. FLANGE CRIPPLING

6.1 INTRODUCTION TO CRIPPLING AND BASIC MECHANICS

Flange crippling is something that is often encountered in the design of highly loaded aerospace structures where paper-thin flange sections are the standard. Crippling is a localized buckling mechanism that is driven by high compressive loads. Figure 22 provides some background on the crippling mechanism. As Figure 22 shows on the far left, the main portion of the extruded section might be stable but its collapse or global buckling is initiated by a localized buckle at its weakest point. These types of structures are outside the realm of hand calculations; however experimentally derived charts exist that allow the designer to make safe design choices about section thicknesses. One designer suggestion is that, if it is not detrimental to the overall design, one can just specify that all flange sections have a $b/t < 5$ and then be free of any crippling consideration.

Figure 23 a simple example is presented that illustrates the challenge of making a direct and easy crippling prediction. From a linear stress analysis perspective, the beam is well designed to handle the applied load with a maximum von Mises stress of 22,000 psi. This linear elastic stress is well below the yield stress of the material at 38,000 psi (2024-T3 from Figure 22).

The Free-Body-Diagram (FBD) in Figure 24 shows a resolved force of 3,000 lbf across the top of the flange. The F_{cr} is calculated as $3,000 \text{ lbf} / (4" * 0.0333") = 22,500 \text{ psi}$ given a flange width edge-to-edge of 4" and the flange thickness is 0.033". If we take the Eigenvalue buckling critical load factor of $0.17 * 22,500 \text{ psi}$, the resulting Eigen- $F_{cr} = 3,800 \text{ psi}$.

To see if this numerical buckling value is relevant, one can use Figure 22 to calculate the F_{cr} for the I-beam. For the section of interest, the t/b ratio is 60 and for 2024-T3 with a yield stress of 38,000 psi, curve 1 would estimate a Chart- $F_{cr} = 10,000 \text{ psi}$.

Unfortunately, we are not even close with the Eigenvalue buckling solution ($Eigen-F_{cr} = 3,800$ versus $Chart-F_{cr} = 10,000$ psi) and although it is conservative we could be adding significant weight to the structure that would be completely underutilized.

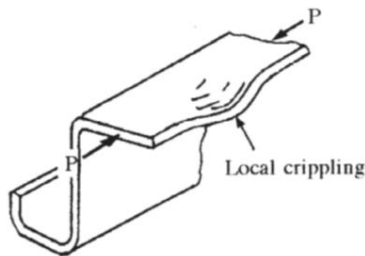
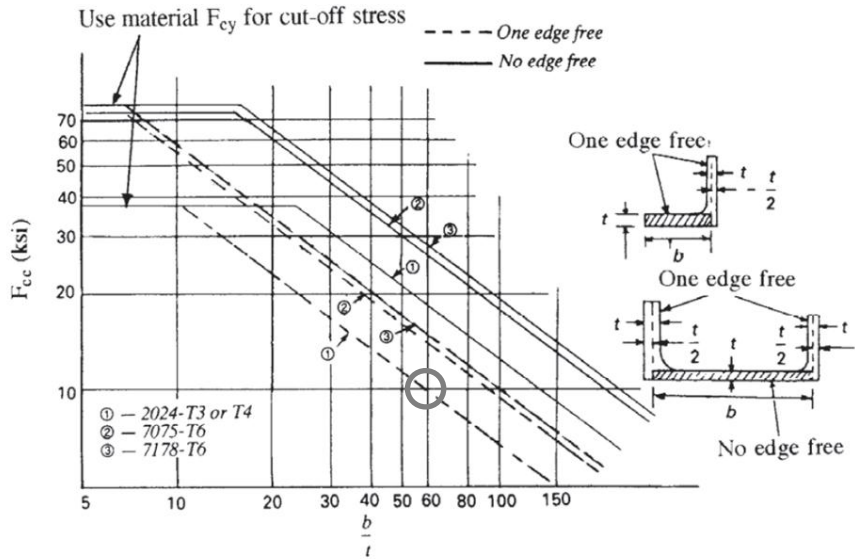

Fig. 10.7.2 Flange Crippling



(2024-T3511, T4, T42, T81 and 7075-T6511 extrusions)

Fig. 10.7.7 Crippling Stress of Extruded Sections

Figure 22: An experimental chart from M. Niu, *Airframe Stress Analysis and Sizing*, 2nd Ed., can be used to determine the crippling load pressure (F_{cr}) of a flange section. The crippling load is the average compressive stress across the flange.

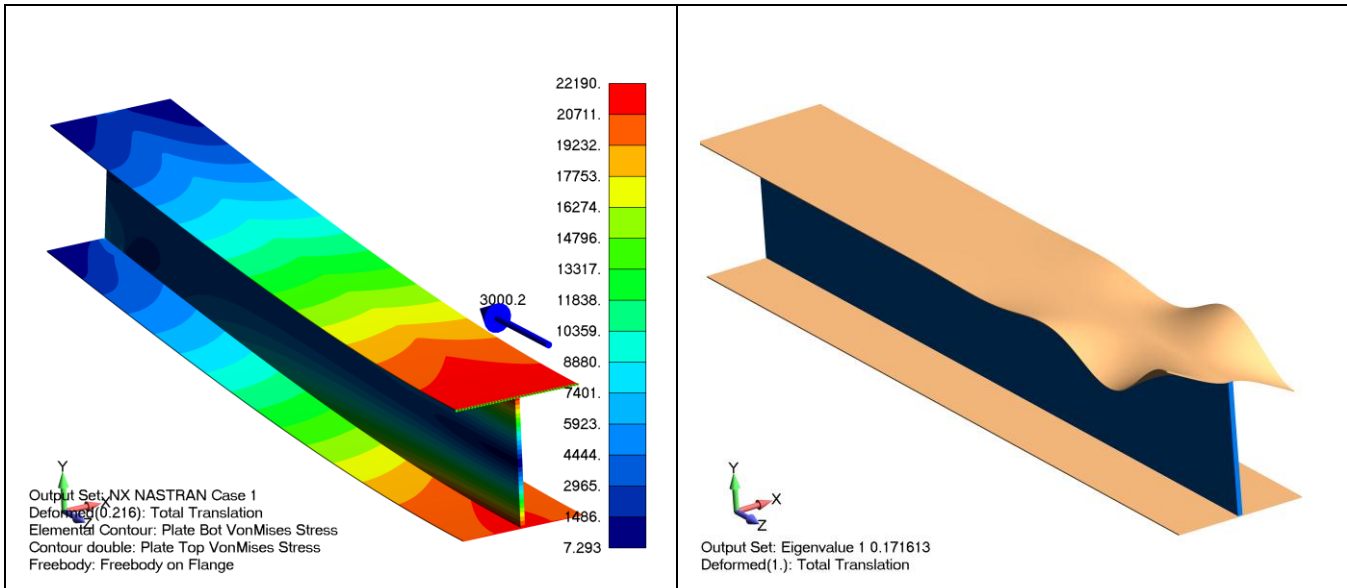

Figure 23: A simple supported beam is given an evenly distributed load across its top flange. The yield stress of the material is 38,000 psi (2024-T3 from Figure 22). A static analysis shows no problems but a buckling analysis indicates it would fail at 0.17x of the applied load.

6.2 GEOMETRIC NONLINEAR ANALYSIS FOR CRIPPLING ANALYSIS

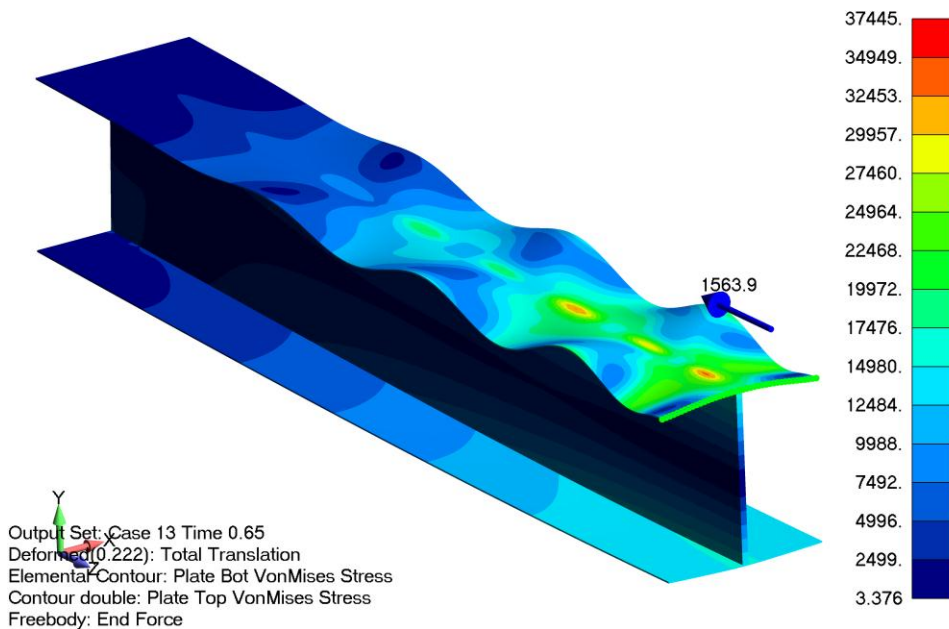

Figure 24: A simply supported I-Beam structure is shown above at its crippling load point.

The free-body-diagram in Figure 24 shows a resolved force of 1564 lbf across the top of the flange. The Nonlinear Geometric- F_{cr} is calculated as $1564 \text{ lbf} / (4'' * 0.0333'') = 11,700 \text{ psi}$.

The difference between Chart- $F_{cr} = 10,000 \text{ psi}$ and Nonlinear Geometric- $F_{cr} = 11,700 \text{ psi}$ is within the expected limits between experimental and numerical results for nonlinear behavior. As such, the difference of 17% is not overly worrisome.

6.3 ANALYST COMMENTARY ON CRIPPLING

Crippling analysis is nothing special in the world of mechanics; it is just a localized buckling phenomenon. What makes it a topic of concern for many aerospace analysts is that it can be easily overlooked since it is not a global buckling mechanism. A checklist for crippling might look like this:

- ✓ Perform overall check on all flanges and webs to see if their b/t values are greater than 5.
- ✓ For flanges/webs with a b/t greater than 5, determine the P_{cr} .
- ✓ Check P_{cr} values against experimentally tabulated values (e.g., see Figure 22).
- ✓ For regions close to the design limit, perform geometric nonlinear analysis to further define crippling behavior.

7. BUCKLING ANALYSIS OF DEEP-DIVING, EIGHT PASSENGER SUBMARINE

Perhaps the most important analysis requirement of a submarine is the determination of the buckling load for the structure. Since underwater craft are subjected to near perfectly hydrostatic pressure loading, buckling will often occur prior to any other type of structural failure.

The following example presents some results from a deep-diving, eight passenger submarine. Additional details on this submarine can be found at www.PredictiveEngineering.com.

7.1 SUBMARINE MODEL AND EIGENVALUE BUCKLING ANALYSIS

Figure 25 shows the pressure hull of the submarine. The hull and battery pods and other general flanges and supports were meshed with plate elements. The main hatches were meshed with brick elements. The pressure load is then applied over all wetted surfaces with load adjustments made to account for the hatches and viewports. When correctly adjusted, the net force is 0.0 over the complete structure.

Figure 26 shows the Eigenvalue buckling prediction of 2.6x. The Eigenmode seems quite reasonable but given the sensitivity of this work, a complete nonlinear analysis is performed.

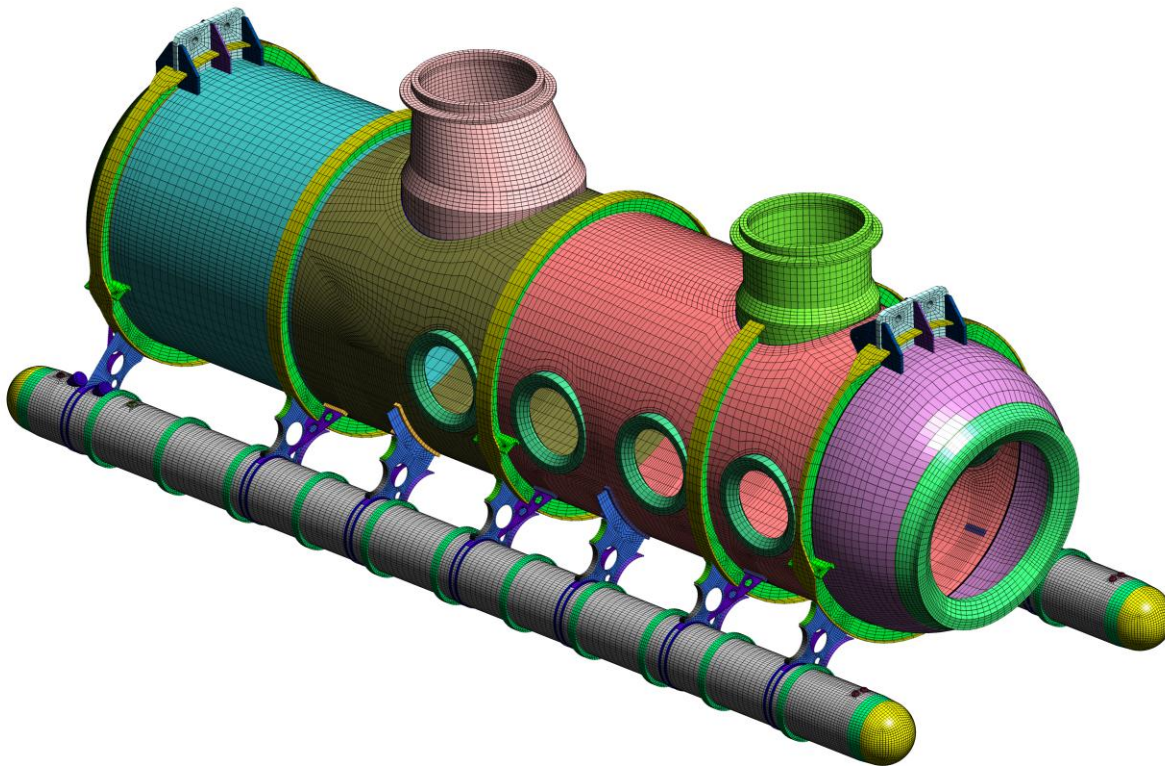
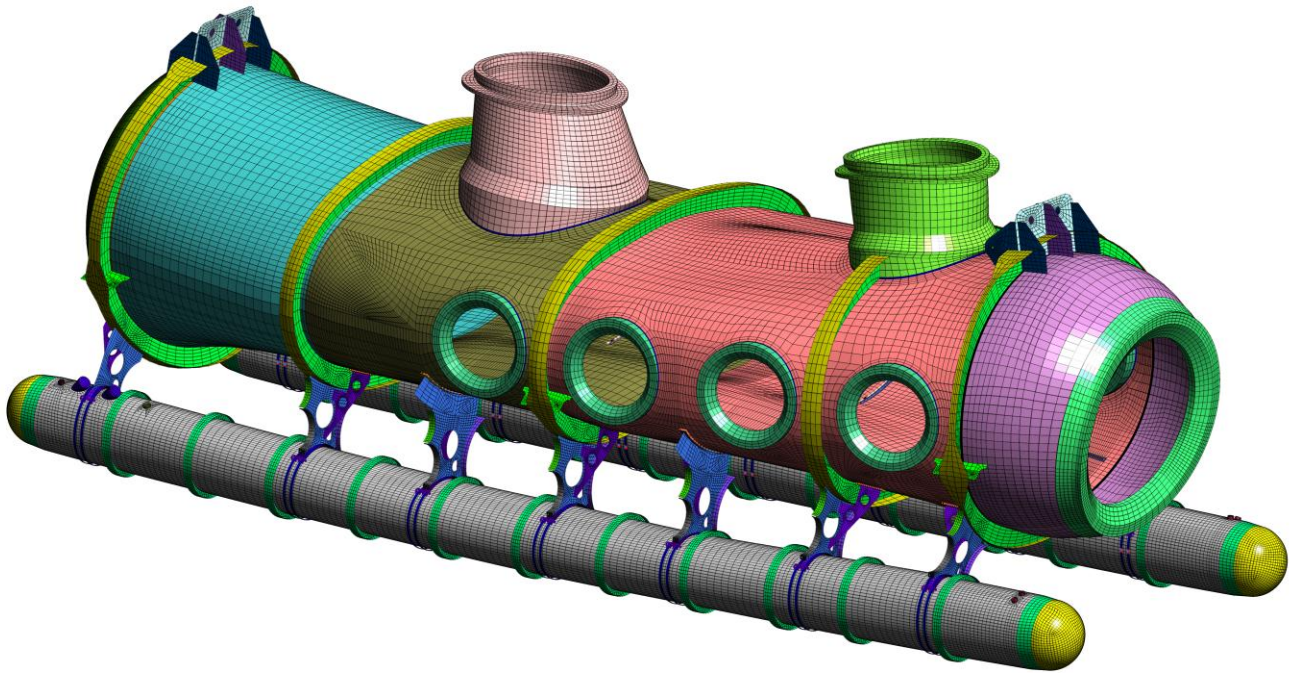

Figure 25: Deep-diving, eight passenger luxury submarine. The FEA work was validated against strain gauged data. The full report on this work can be seen at www.PredictiveEngineering.com.



Output Set: Eigenvalue 1 2.579274
Deformed(1.): Total Translation

Figure 26: The NX Nastran Eigenvalue buckling analysis predicts a buckling factor of 2.6x.

7.2 NONLINEAR BUCKLING ANALYSIS OF SUBMARINE

The full nonlinear results shown in Figure 27 indicate that the onset of buckling is near 2.75x of the applied load. This is somewhat close to the Eigenvalue results at 2.6x.

It is interesting to note that the full nonlinear model indicates an early buckling onset (Figure 28) of the main hatch at a load factor closer to 2.5x. What is perhaps more important is that the results are nicely bracketed and one can have a high confidence that the buckling behavior has been captured.

LS-DYNA Nonlinear Buckling Analysis
Time = 0.054999

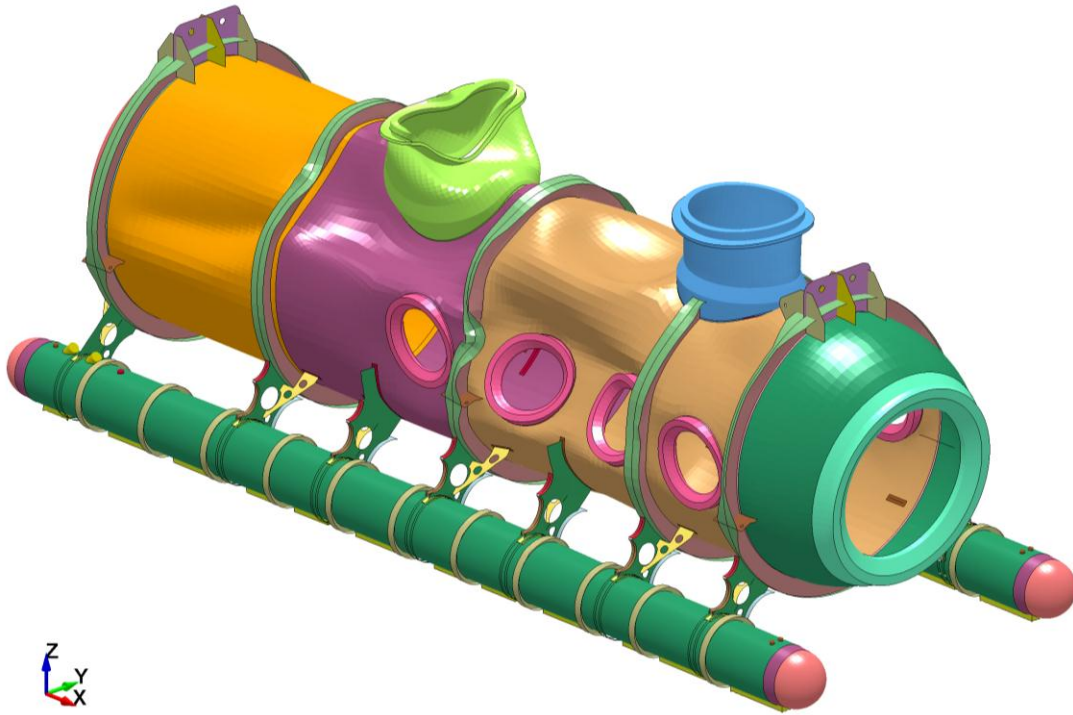

LS-DYNA Nonlinear Buckling Analysis
Time = 0.060999

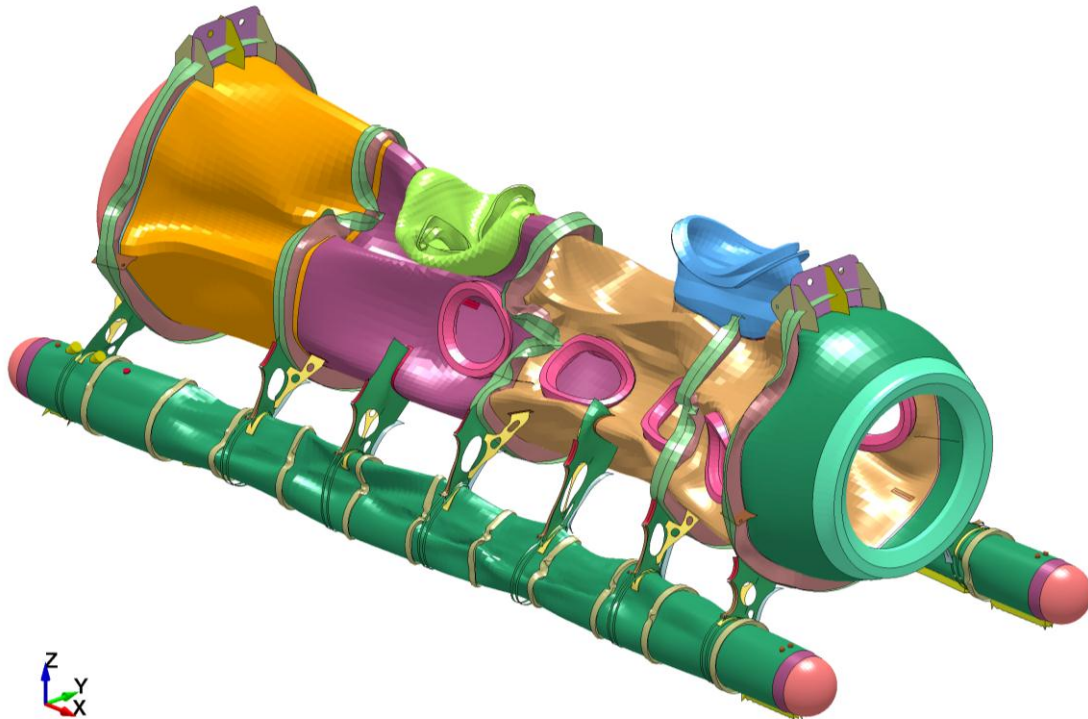

Figure 27: Submarine hull undergoing buckling. The hull starts to buckle at a load factor of 2.7x.

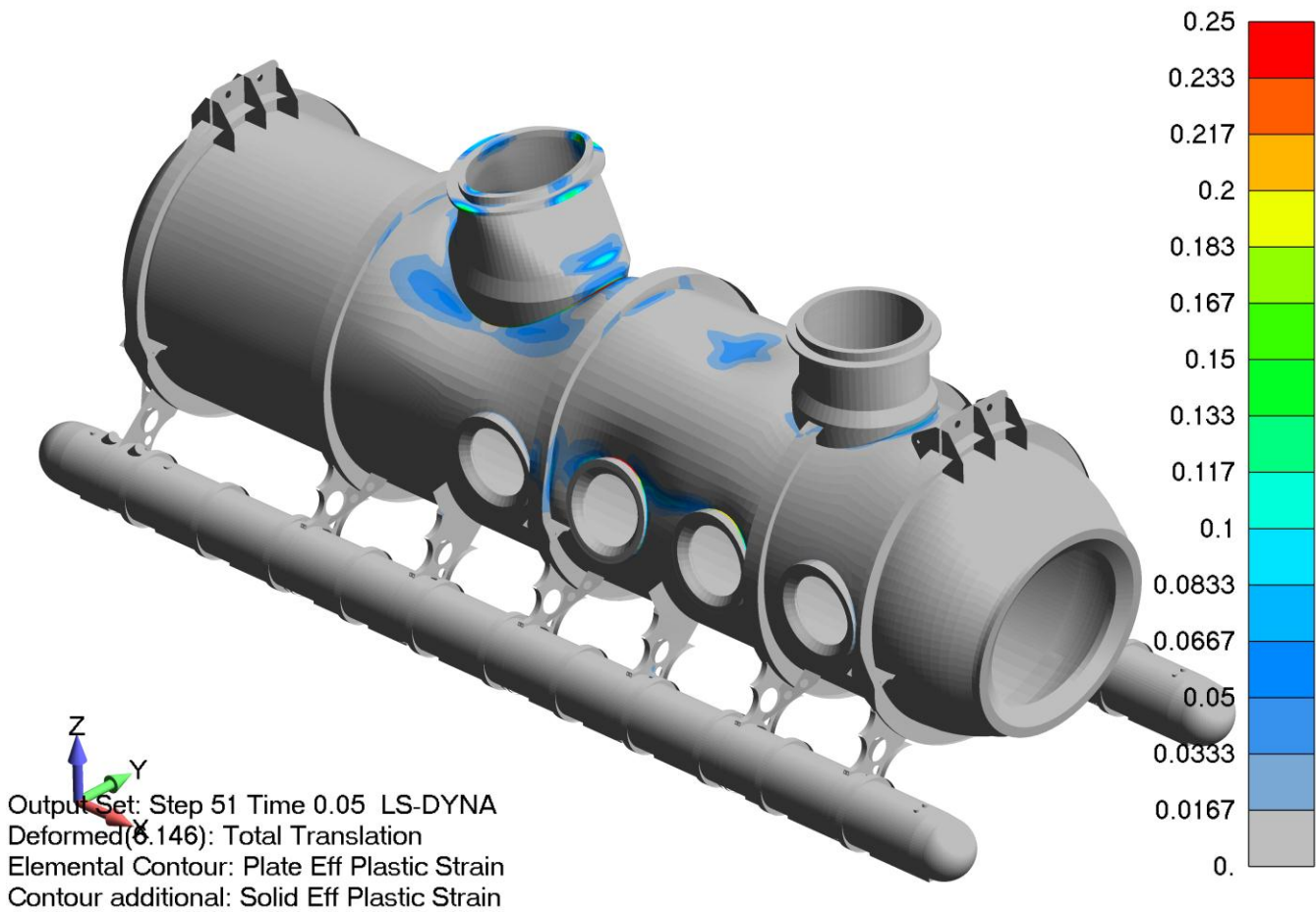

Figure 28: Plastic strain around the main hatch indicates the start of buckling collapse at 2.5x load factor.



8. WHAT WE DO AT PREDICTIVE ENGINEERING

We are a small, specialized engineering software consultancy that dedicates itself to providing the best possible engineering service to our clients.

Our work process is defined by listening to our clients and being honest brokers about our abilities, schedules and engineering software that we represent.

During our sixteen years of business, every client can be considered a reference client. Equally important, we have successfully completed over 800+ projects with not one analysis failure. In the briefest possible terms, let us say that we stand by our work and take each project very seriously.

If you would like to talk to us about your next analysis project or look into buying Femap, NX Nastran or LS-DYNA, please give us a call.

Sincerely,

Predictive Engineering, Inc.

503 | 206 | 5571

